

FURUNO

OPERATOR'S MANUAL

*MARINE VHF
RADIOTELEPHONE*

MODEL **FM-4721**

 FURUNO ELECTRIC CO., LTD.

www.furuno.com

IMPORTANT NOTICES

General

- This manual has been authored with simplified grammar, to meet the needs of international users.
- The operator of this equipment must read and follow the descriptions in this manual. Wrong operation or maintenance can cancel the warranty or cause injury.
- Do not copy any part of this manual without written permission from FURUNO.
- If this manual is lost or worn, contact your dealer about replacement.
- The contents of this manual and equipment specifications can change without notice.
- The example screens (or illustrations) shown in this manual can be different from the screens you see on your display. The screens you see depend on your system configuration and equipment settings.
- Save this manual for future reference.
- Any modification of the equipment (including software) by persons not authorized by FURUNO will cancel the warranty.
- All brand and product names are trademarks, registered trademarks or service marks of their respective holders.

How to discard this product

Discard this product according to local regulations for the disposal of industrial waste. For disposal in the USA, see the homepage of the Electronics Industries Alliance (<http://www.eiae.org/>) for the correct method of disposal.

How to discard a used battery

Some FURUNO products have a battery(ies). To see if your product has a battery, see the chapter on Maintenance. Follow the instructions below if a battery is used. Tape the + and - terminals of battery before disposal to prevent fire, heat generation caused by short circuit.

In the European Union

The crossed-out trash can symbol indicates that all types of batteries must not be discarded in standard trash, or at a trash site. Take the used batteries to a battery collection site according to your national legislation and the Batteries Directive 2006/66/EU.

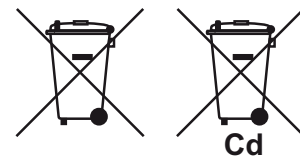

In the USA

The Mobius loop symbol (three chasing arrows) indicates that Ni-Cd and lead-acid rechargeable batteries must be recycled. Take the used batteries to a battery collection site according to local laws.

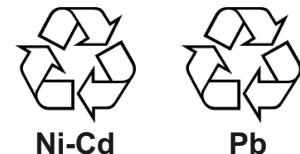



In the other countries

There are no international standards for the battery recycle symbol. The number of symbols can increase when the other countries make their own recycle symbols in the future.













SAFETY INSTRUCTIONS



The operator and installer of this equipment must read the safety instructions before attempting to install or operate the equipment.

 WARNING	Indicates a potentially hazardous situation which, if not avoided, could result in death or serious injury.
 CAUTION	Indicates a potentially hazardous situation which, if not avoided, could result in minor or moderate injury.

 Warning, Caution	 Prohibitive Action	 Mandatory Action
--	--	--

 WARNING	
	Do not open the equipment. The equipment uses high voltage that can cause electrical shock. Refer any repair work to a qualified technician.
	If water leaks into the equipment or something is dropped into the equipment, immediately turn off the power at the switchboard. Fire or electrical shock can result.
	If the equipment is giving off smoke or fire, immediately turn off the power at the switchboard. Fire or electrical shock can result.
	If you feel the equipment is acting abnormally or giving off strange noises, immediately turn off the power at the switchboard and contact a FURUNO service technician.

 WARNING	
	Do not disassemble or modify the equipment. Fire, electrical shock or serious injury can result.
	Make sure no rain or water splash leaks into the equipment. Fire or electrical shock can result if water leaks into the equipment.
	Do not place liquid-filled containers on or near the equipment. Fire or electrical shock can result if a liquid spills into the equipment.
	Do not operate the equipment with wet hands. Electrical shock can result.
	Use the proper fuse. Use of the wrong fuse can cause fire or electrical shock.

 CAUTION	
	Do not touch any part of the antenna when the equipment is transmitting. Electrical shock can result.

WARNING

Do not open the equipment unless totally familiar with electrical circuits.

The equipment uses high voltage that can cause electrical shock.



Turn off the power at the mains switchboard before beginning the installation. Post a warning sign near the switchboard to indicate that power should not be applied while the equipment is being installed.

Electrical shock, serious injury or fire can result if the power is not turned off or is applied while the equipment is being installed.



RADIO FREQUENCY RADIATION HAZARD

Distances at which RF radiation level of 100, 10 and 5.05 W/m² are shown below.

100 W/m²: Not applicable
 10 W/m²: Not applicable
 5.05 W/m²: 1.0 m

CAUTION

Confirm that the power supply voltage is compatible with the voltage rating of the equipment.

Connection to the wrong power supply can cause fire or damage the equipment.



Follow the compass safe distances shown in the table below to prevent interference to a magnetic compass.

	Standard compass	Steering compass
Transceiver Unit FM-4721	1.70 m	1.10 m
Handset HS-4721	0.70 m	0.45 m

TABLE OF CONTENTS

FOREWORD	vii
SYSTEM CONFIGURATION	viii
1. GETTING STARTED.....	1-1
1.1 Emergency Call (CH16)	1-1
1.2 How to Call Another Vessel (CH16 or CH9)	1-1
1.3 How to Make Telephone Calls	1-2
1.4 Channels 13 and 67 (USA channel group only).....	1-2
2. OPERATION	2-1
2.1 Controls.....	2-1
2.1.1 Transceiver Unit.....	2-1
2.1.2 Handset HS-4721.....	2-3
2.2 Reception	2-5
2.3 Transmission.....	2-5
2.4 Transmit Timeout Timer (TOT)	2-6
2.5 Simplex/Duplex Channel Use	2-6
2.6 International, Canada, and USA Mode	2-6
2.7 Backlight Adjustment.....	2-6
2.8 NOAA Weather Channels	2-7
2.8.1 NOAA weather alert	2-7
2.8.2 NOAA weather alert test	2-7
2.9 Dual Watch (To CH16).....	2-8
2.10 Scanning	2-8
2.10.1 How to select the scan type	2-8
2.10.2 How to program the scan memory	2-9
2.10.3 Memory scanning (M-SCAN)	2-9
2.10.4 Priority scanning (P-SCAN).....	2-10
2.11 How to Preset Channels (0-7): Instant Access	2-10
2.11.1 How to preset channels.....	2-10
2.11.2 How to activate preset channels	2-11
2.11.3 How to delete preset channels.....	2-11
2.12 PA HAIL, FOG HORN Operation	2-11
2.12.1 PA HAIL mode	2-11
2.12.2 FOG HORN mode.....	2-12
2.13 Intercom Operation	2-13
2.13.1 Communication	2-13
2.13.2 How to call on the Intercom.....	2-14
2.14 Bluetooth Operation (option).....	2-14
2.14.1 Pairing	2-14
2.14.2 Operation	2-15
2.14.3 VOX feature	2-15
2.14.4 Battery saver	2-16
2.15 Voice Scrambler (option).....	2-16
3. DIGITAL SELECTIVE CALLING	3-1
3.1 General	3-1
3.2 Maritime Mobile Service Identity (MMSI)	3-1
3.2.1 What is an MMSI?.....	3-1
3.2.2 How to enter your MMSI number	3-1
3.3 DSC Distress Alert	3-2
3.3.1 How to transmit a DSC Distress Alert	3-2

3.3.2	How to receive a DSC Distress Alert.....	3-5
3.4	All Ships Call	3-6
3.4.1	How to transmit an All Ships call	3-6
3.4.2	How to receive an All Ships call	3-7
3.5	Individual Call	3-7
3.5.1	How to register DSC stations to the Individual Directory	3-7
3.5.2	How to select the Individual call reply method	3-8
3.5.3	How to select the Individual call acknowledge method	3-9
3.5.4	Individual/Group call ringer.....	3-9
3.5.5	How to transmit an Individual call.....	3-10
3.5.6	How to receive an Individual call	3-11
3.6	DSC Log.....	3-13
3.6.1	Transmitted call log	3-13
3.6.2	Distress log.....	3-13
3.6.3	Other call log	3-13
3.6.4	How to delete calls from a log	3-14
3.7	Group Call	3-14
3.7.1	How to register DSC stations to the Group Directory	3-14
3.7.2	How to transmit a Group call	3-16
3.7.3	How to receive a Group call	3-17
3.8	Position Request Call	3-18
3.8.1	How to set up a position request reply	3-18
3.8.2	How to set up the position request ringer	3-18
3.8.3	How to transmit a Position Request call to another vessel	3-19
3.8.4	When you receive a Position Request call	3-20
3.9	Position Report Call.....	3-20
3.9.1	How to enable, disable the position report ringer	3-20
3.9.2	How to transmit a Position Report call	3-21
3.9.3	When you receive a Position Report call.....	3-22
3.10	Auto DSC Polling.....	3-23
3.10.1	Selecting stations to be automatically polled (tracked)	3-23
3.10.2	Enable/Disable auto DSC polling	3-24
3.11	Auto CH Switch Time	3-24
3.12	DSC Test.....	3-25
3.12.1	How to make a DSC test call with MMSI in the Individual Directory.....	3-25
3.12.2	How to make a DSC test call by manually entering MMSI	3-26
4.	GENERAL SETUP	4-1
4.1	Display Contrast	4-1
4.2	Time Offset.....	4-1
4.3	Time Area	4-2
4.4	Time Notation	4-2
4.5	Units of Measurement	4-2
4.6	COG Display Format	4-3
4.7	Manual Input of the Position (Lat/Lon).....	4-3
4.8	Key Beep	4-4
4.9	Treble and Bass Audio Tone Control	4-4
4.10	Fog Alert Tone Frequency.....	4-4
4.11	How to Name the Radio or Handset.....	4-5
4.12	Soft Keys	4-6
4.12.1	Transceiver unit.....	4-6
4.12.2	Handset HS-4721	4-7
4.13	Calendar Setup.....	4-7
4.14	How to Set the Timeouts	4-9

TABLE OF CONTENTS

5	CHANNEL SETUP.....	-1
5.1	CH Group.....	5-1
5.2	Scan Memory.....	5-1
5.3	Scan Type.....	5-2
5.4	Scan Resume.....	5-2
5.5	Priority CH.....	5-2
5.6	Weather Alert Setup.....	5-3
5.7	Channel Naming.....	5-4
6	ATIS SETUP.....	-1
6.1	ATIS Code Programming.....	6-1
6.2	ATIS Channel Group.....	6-2
7	ANTENNA RULES AND TROUBLESHOOTING.....	-1
7.1	General Maintenance.....	7-1
7.2	Troubleshooting Chart.....	7-2
7.3	How to Replace the Fuse.....	7-3
7.4	How to Clear the Memory.....	7-3
7.5	How to Reset the Microprocessor.....	7-3
7.6	Daily Test.....	7-4
8	INSTALLATION.....	-1
8.1	Transceiver Unit.....	8-1
	8.1.1 Desktop or overhead mount.....	8-1
	8.1.2 Flush mount (option).....	8-2
8.2	Antenna.....	8-2
8.3	Coaxial Cable.....	8-3
8.4	Electrical Connections.....	8-3
8.5	Accessory Cable.....	8-5
8.6	Handset HS-4721.....	8-6
	8.6.1 How to use an external speaker.....	8-8
8.7	How to Set up the Equipment from the Menu.....	8-8
	8.7.1 How to set time offset to show local time.....	8-8
	8.7.2 How to show local time or UTC time.....	8-9
	8.7.3 How to set the time notation.....	8-9
	8.7.4 How to select GPS COG format.....	8-9
8.8	Optional Equipment.....	8-10
	8.8.1 Bluetooth Adapter Unit BU-1.....	8-10
	8.8.2 Voice Scrambler F P-42.....	8-11
APPENDIX	1 CHANNEL ASSIGNMENTS MENU TREE.....	AP-1
SPEAKER	ATIS.....	SP-1
INDEX	N-1

FOREWORD

A Word to the Owner of the FM-4721

FURUNO Electric Company thanks you for purchasing the FM-4721 Marine VHF Radiotelephone. We are confident you will discover why the FURUNO name has become synonymous with quality and reliability.

For over 60 years FURUNO Electric Company has enjoyed an enviable reputation for quality and reliability throughout the world. This dedication to excellence is furthered by our extensive global network of agents and dealers.

Your equipment is designed and constructed to meet the rigorous demands of the marine environment. However, no machine can perform its intended function unless properly installed and maintained. Please carefully read and follow the operation, installation and maintenance procedures set forth in this manual.

We would appreciate feedback from you, the end-user, about whether we are achieving our purposes.

Thank you for considering and purchasing FURUNO.

Features

The FURUNO FM-4721 is a Marine VHF Radiotelephone designed for use in the frequency range of 156.025 to 163.275 MHz. The FM-4721 can be powered with 10.8 to 15.6 VDC power and has a switchable RF output power of 1 Watt or 25 Watts.

The FM-4721 operates on all currently allocated marine channels. Channels are switchable for use with USA, International, or Canadian regulations. Emergency CH16 can be immediately selected by pressing the **16/9** key. NOAA weather channels (where available) can also be accessed immediately by pressing the **CLR/WX** key.

The FM-4721 incorporates DSC (Digital Selective Calling) Class D facilities that comply with ITU-R M.493-12 (DSC Class D). Class D operation provides continuous watch on DSC CH70 even if the radio is receiving a call.

The main features are

- Class D DSC (Digital Selective Calling) with Distress, Individual and All Ship calls
- Navigation information (LAT/LON, SOG, COG) shown on the display*
- Navigate to a DSC Distress Position*
- Automatic DSC Position Poll request to up to four separate vessels
- Menu system with user-programmable soft keys
- Dedicated channel 70 receiver for continuous DSC watch
- Submersible IPX-7 rating (1 meter for 30 minutes)
- 30 Watt PA/Loudhailer (option) with pre-programmed fog signals and listenback facility
- ClearVoice noise-cancelling microphone with channel selector and **16/9** key
- Handset HS-4721 can operate as a remote station
- Intercom facility between Handset and Radio
- Optional Bluetooth Adapter Unit enables communication with bluetooth devices
- Optional Voice Scrambler provides secure communications with other so equipped FM-4721

*: Requires external GPS navigator.

SYSTEM CONFIGURATION

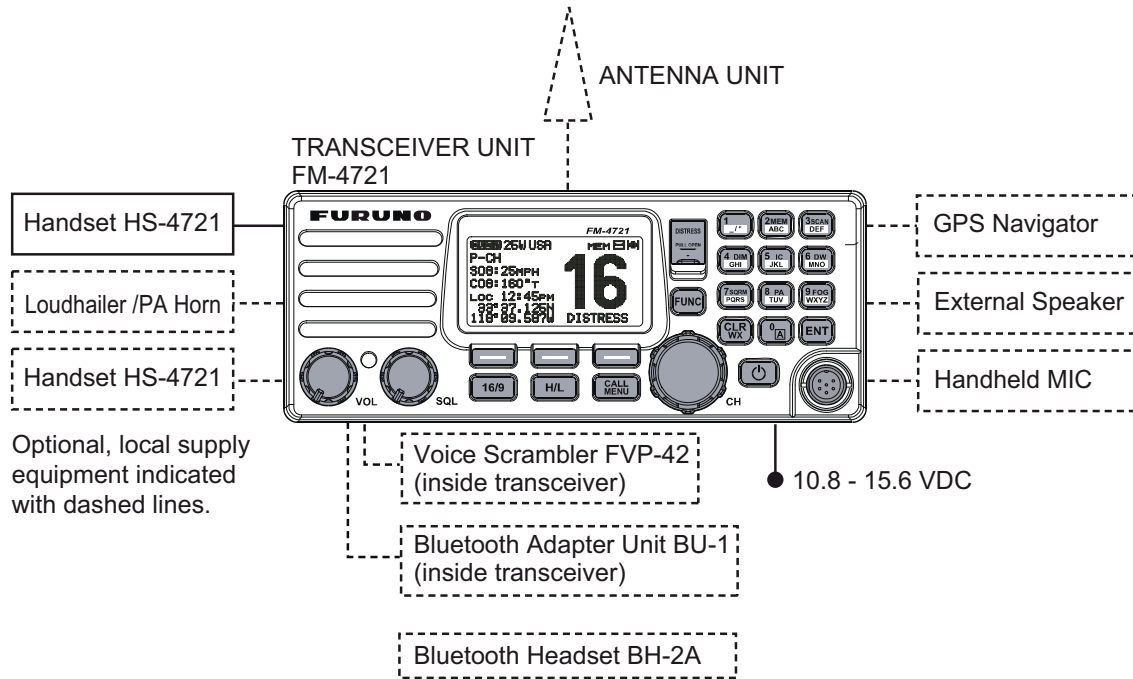

1. GETTING STARTED

1.1 Emergency Call (CH16)

CH16 is known as the Hail and Distress Channel. An emergency may be defined as a threat to life or property. In such instances, be sure the transceiver is on and set to CH16. Then use the following procedure:

1. Press the microphone's push-to-talk (PTT) switch and say "**Mayday, Mayday, Mayday**. This is XXXXX, XXXXX, XXXXX" (your vessel's name).
2. Then repeat once: "**Mayday, XXXXX**" (your vessel's name).
3. Report your position in latitude/longitude, or give a true or magnetic bearing (state which) to a well-known landmark such as a navigation aid or geographic feature such as an island or harbor entry.
4. Explain the nature of your distress (sinking, collision, aground, fire, piracy, life-threatening injury, etc.).
5. State the kind of assistance you desire (pumps, medical aid, etc.).
6. Report the number of persons aboard and condition of any injured.
7. Estimate the present seaworthiness and condition of your vessel.
8. Give your vessel's description: length, design (power or sail), color and other distinguishing marks. The total transmission should not exceed one minute.
9. End the message by saying "**OVER**". Release the microphone switch and listen.
10. If there is no answer, repeat the above procedure. If there is still no response, try another channel.

Note: The FM-4721 has DSC Distress calling, which can send a distress call digitally to all ships with compatible DSC radios. Refer to chapter 3 "DIGITAL SELECTIVE CALLING".

1.2 How to Call Another Vessel (CH16 or CH9)

CH16 (or CH9, depending on area) should be used as the calling channel for initial contact with another vessel. However, its primary purpose is for emergency communications and should be monitored at all times when not using other channels.

It is monitored by Coast Guard stations in all countries and other vessels.

The use of CH16 should be limited to making initial contact only. Calling should not exceed one minute, but may be repeated at two-minute intervals.

Prior to making contact with another vessel, refer to the channel charts in the Appendix and select an appropriate channel (working channel) for use after initial contact. Monitor the proposed channel to ensure you won't be interrupting other traffic and then go back to CH16 to make your initial call.

When channel 16 is clear, state the name of the vessel you wish to call and then "**this is**" followed by the name of your vessel and your vessel callsign. When the other vessel returns your call, immediately request another channel by saying "**go to**", the num-

1. GETTING STARTED

ber of the other channel, and "**over**". Then switch to the new channel. When the new channel is not busy, call the vessel.

After a transmission, say "**over**", and release the **PTT** (Push-To-Talk) switch on the microphone. When all communication with the vessel is completed, end the last transmission by stating your callsign and the word "**out**". Note that it is not necessary to state your callsign with each transmission, only at the beginning and end of the contact.

Remember to return to CH16 when not using another channel. Some radios automatically monitor CH16 even when set to other channels or when scanning.

1.3 How to Make Telephone Calls

To make a radiotelephone call, use a channel designated for this purpose. The fastest way to learn which channels are used for radiotelephone traffic is to ask at a local marina. Channels available for such traffic are designated **Public Correspondence** channels on the channel charts in the Appendix. Some examples for USA use are Channels 24, 25, 26, 27, 28, 84, 85, 86, and 87. Call the marine operator and identify yourself by your vessel's name. The marine operator then asks you how you want to pay for the call (telephone credit card, collect, etc.) and then link your radio transmission to the telephone lines.

The marine telephone company managing the VHF channels you are using may charge a link-up fee in addition to the cost of the call.

1.4 Channels 13 and 67 (USA channel group only)

Channel 13 is used at docks and bridges and by vessels maneuvering in port. Messages on this channel must concern navigation only, such as meeting and passing in restricted waters.

Channel 67 is used for navigational traffic between vessels.

By regulation, power is normally limited to 1 Watt on these channels. Your radio is programmed to automatically reduce power to this limit on these channels. However, in emergency situations it may be necessary to temporarily use a higher power. See page 2-1 (**H/L** key) for how to temporarily override the low-power limit on these two channels.

2. OPERATION

2.1 Controls

This section describes the controls of the Transceiver Unit (including the optional microphone) and the Handset HS-4721.

2.1.1 Transceiver Unit

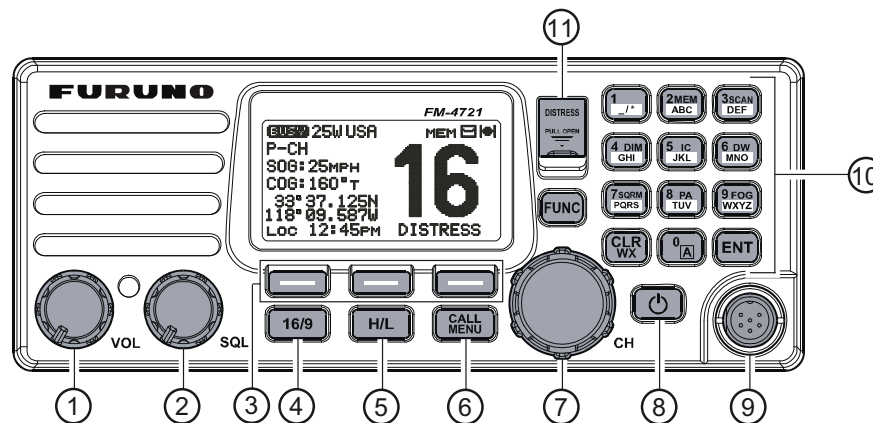

No.	Control	Description
1	VOL (Volume Control Knob)	<ul style="list-style-type: none"> Adjust the audio volume level. Turn this knob clockwise to increase the audio volume level. Control the listenback volume in the PA or Fog mode. <p>Note: Turn off the set with minimum volume. When you turn on the set, adjust the volume to a comfortable level. This allows you to hear distress calls and raw voice clearly.</p>
2	SQL (Squelch Control)	Adjust this control clockwise to set the point at which random noise on the channel does not activate the audio circuits but a received signal does. This point is called the squelch threshold. Further adjustment of the squelch control may degrade reception of wanted transmissions.
3	Soft keys	The three soft keys functions can be customized on the Setup Menu. See section 4.12 "Soft Keys". When one of the soft keys is pressed briefly, all the functions of the soft keys appear above their associated keys.
4	16/9	<ul style="list-style-type: none"> Momentary press: Recall CH16 from any channel location. Long press: Recall CH9. (CH9 is used in some parts of the world as an alternative calling channel to CH16.) Press the key again to return to the previously selected working channel.
5	H/L	Toggle between 25 W (High) and 1 W (Low) power. When the TX output power is set to "Low" while the transceiver is on channel 13 or 67, the output power is temporarily switched from "Low" to "High" power until the PTT switch is released. The H/L key does not function on transmit inhibited and low power only channels.
6	CALL/MENU	<ul style="list-style-type: none"> Momentary press: Open the [DSC Menu]. Long press: Open the [Setup Menu].

2. OPERATION

N .		
7		Select channels and select menu items. The ▲ and ▼ keys on the microphone can also be used to select channels and menu items. In the PA or Fog mode, change the output volume of the connected horn speaker.
8	 (POWER)	Power the transceiver on and off. To turn the transceiver on, press and hold this key until the LCD turns on. To turn it off, press and hold this key until the LCD turns off. When the power is turned on, the transceiver is set to the last-selected channel.
9	MIC connector	Connector for the supplied noise-canceling speaker microphone.
10	1	When in the radio mode, this key directly inputs the digit 1 in a channel number.
	E	R Directly input the digit 2 in a channel number. UN → E Memorize the selected channel into the transceiver scan memory for scanning. Repeat the same procedure (UN → E) to delete the channel from the scan memory. See section 2.10 Scanning for details.
	S AN	R Directly input the digit 3 in a channel number. UN key→ S AN key Start and stop scanning on programmed channels. This function depends on scanning type setting. See section 2.10 Scanning for details.
	4	R Directly input the digit 4 in a channel number. UN key→ 4 key Access the LCD Dimmer menu. See section 2.7 Backlight Adjustment for details.
		R Directly input the digit 5 in a channel number. UN key→ key Activate the intercom mode between the radio and the Handset. See section 2.13 Intercom Operation for details.
		R Directly input the digit 6 in a channel number. UN key→ key Scan for voice communications on the priority channel and another selected channel until a signal is received on either channel (Dual Watch). See section 2.9 Dual Watch (To CH16) for details.
	S R	R Directly input the digit 7 in a channel number. UN key→ S R key Operate the voice Scrambler function when the optional F P-42 voice Scrambler Unit is installed. See section 2.15 voice Scrambler (option) for details.
	PA	R Directly input the digit 8 in a channel number. UN key→ PA key Operate the 30 Watt PA function. See section 2.12 PA HAIL, FOG HORN Operation for details.
	G	R Directly input the digit 9 in a channel number. UN key→ G key Operate the Fog Horn function. See section 2.12 PA HAIL, FOG HORN Operation for details.
		In the radio mode, directly input the digit 0 in a channel number.
	LR	Cancel the menu selection and/or key input. Press and hold the key to recall the previously selected NOAA weather channel from any channel. Press and hold the key again to revert to the previously selected working channel.
ENT	Confirm the menu selection and/or key input.	
UN	Activate the Alternate key function.	
11	STRESS	Send a DSC Distress Alert. See section 3.3.1 How to transmit a DSC Distress Alert .

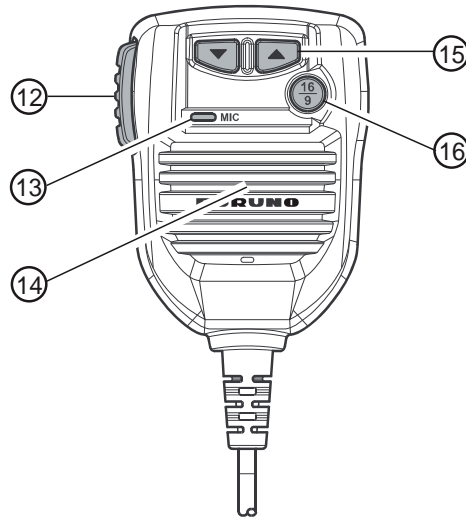

No.	Control	Description
12	PTT switch (Push-To-Talk Switch)	Radio mode, PTT switch pressed: The transmitter is enabled for voice communications with another vessel. PA mode: Press the PTT switch to amplify your voice over a PA horn. HS-4721 Handset connected and intercom mode enabled: Press the PTT switch to enable voice communications between the FM-4721 and the HS-4721.
13	Microphone	The microphone has Clear Voice Noise Reduction Technology, which reduces the amount of background (wind, engine) noise transmitted. Note: Position your mouth about 1.5 cm away from the microphone hole and speak in a normal voice.
14	Microphone speaker	Talk into the speaker to transmit your voice.
15	▲, ▼	The ▲ and ▼ on the microphone function the same as the CH knob on the front panel of the transceiver.
16	16/9	<ul style="list-style-type: none"> • Momentary press: Recall CH16 from any channel location. • Long press: Recall CH9. (CH9 is used in some parts of the world as an alternative calling channel to CH16.) Press the key again to revert to the previously selected working channel.

2.1.2 Handset HS-4721

The HS-4721 Handset remotely operates all VHF, DSC, setup menus, and PA/Fog modes. The HS-4721's operation is same as FM-4721 except the receiver audio volume setting and squelch level setting. The HS-4721 is supplied with 7 m of routing cable and can be extended up to 21 m using three 7 m extension cables model CT-100. The Intercom feature can be used between the HS-4721 and the FM-4721. In addition, speaker wires are supplied at the panel mount of the routing cable to connect an external speaker. This can be useful when it is difficult to hear voice over the handset, because of noisy environment.

2. OPERATION

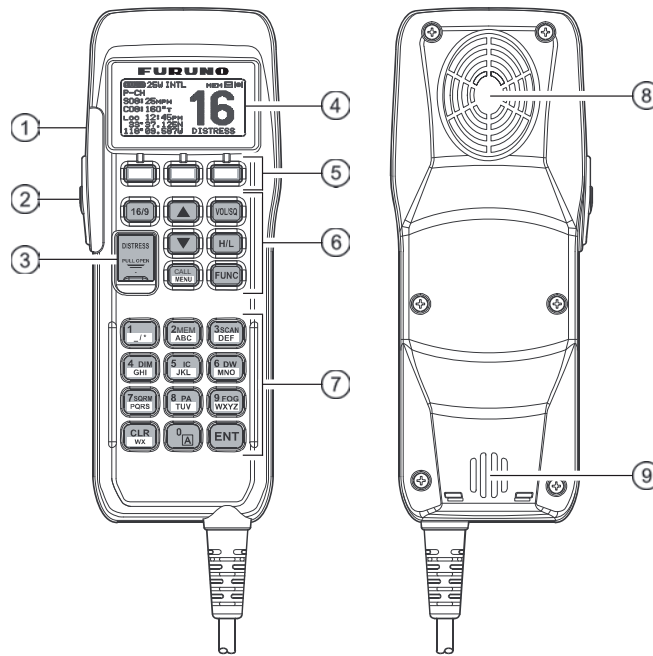

No.	Control	Description
1	(POWER)	Press and hold down this key to turn the transceiver and Handset on or off.
2	PTT switch (Push-To-Talk Switch)	Push this key to enable the transmitter.
3	DISTRESS	Transmit a DSC Distress Alert. See chapter 3.
4	Display	Full dot matrix display.
5	Soft keys	These three key's functions can be customized by the [Setup Menu] mode. When press one of these key briefly, the key functions appear at the bottom of the display. See section 4.12.2 Soft Keys.
6	16/9	<ul style="list-style-type: none"> • First press: CH16 is immediately selected. • Second press: Recall the last selected channel. • Press and hold: Select channel 9.
	▲, ▼	These keys are used to select channels, adjust the volume and squelch level, and to select DSC calls, DSC setup and Radio setup function.
	VOL/SQ (Volume Control / Squelch Control)	<ul style="list-style-type: none"> • First press: Volume adjustment mode • Second press: Squelch adjustment mode • Third press: Exit adjustment mode When in volume or squelch mode, press the ▲ or ▼ keys to adjust the level.
	H/L	Toggle between high and low power. When the H/L key is pressed while the transceiver is on CH13 or CH67, the power is temporarily switched from LO to HI until the PTT switch is released. The H/L key is inoperative on transmission inhibited and low-power only channels.
	CALL/MENU	<ul style="list-style-type: none"> • Press this key to access the [DSC MENU]. • Press and hold this key to access the [SETUP MENU].
	FUNC	Press this key to activate the Alternate key function.
7	See respective description on page 2-2.	
8	Speaker	The internal speaker is located here.
9	Microphone	The internal ClearVoice Noise Canceling mic is located here. When transmitting, position your mouth about 1.5 centimeter away from the small mic hole. Speak slowly and clearly into the microphone.

2.2 Reception

1. After the transceiver has been installed, ensure that the power supply and antenna are properly connected.
2. Press and hold the **PWR** key until the radio turns on.
3. Rotate the **SQL** knob fully counterclockwise. This state is known as "squelch off".
4. Rotate the **VOL** knob clockwise until noise or audio from the speaker is at a comfortable level.
5. Rotate the **SQL** knob clockwise until the random noise just disappears. This state is known as the "squelch threshold".
6. Rotate the **CH** knob to select a channel. Refer to the channel chart in the Appendix for available channels.
7. The numeric keys on the front panel may be used to directly select channels. For example, to select CH68:
 - 1) Press the **6/DW** key.
 - 2) Press the **8/PA** key.
 - 3) Press the **ENT** key.

In the USA and Canadian modes, press and hold down the **0** key to select the "A" channel. For example, to select CH22A:

 - 1) Press the **2/MEM** key.
 - 2) Press the **2/MEM** key.
 - 3) Press the **0** key until "A" appears to the right of the channel number.
 - 4) Press the **ENT** key.
8. When a message is received, adjust the volume to the desired listening level. The **BUSY** indicator on the display indicates communications is being received.

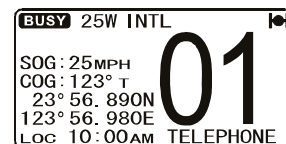

2.3 Transmission

1. Do steps 1 through 6 in section 2.2 "Reception".
2. Before transmitting, monitor the channel to ensure it is clear.
3. Press the **PTT** (push-to-talk) switch on the microphone. The **T X** indicator appears on the display.
4. Speak slowly and clearly into the microphone.
5. When the transmission is finished, release the **PTT** switch.

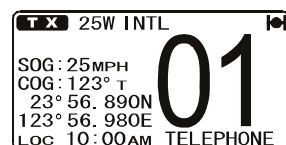

Note: This is a noise-canceling microphone. Position the slot labeled "MIC" within 1.5 cm from your mouth for optimum performance.

2.4 Transmit Timeout Timer (TOT)

When the **PTT** switch on the microphone is pressed continuously, transmit time is limited to five minutes. This limits unintentional transmissions due to a stuck **PTT** switch. About 10 seconds before automatic transmitter shutdown, a warning beep sounds from the speaker(s). The transceiver automatically goes to the RX mode, even if the **PTT** switch is continually held down. To transmit again, the **PTT** switch must first be released and then pressed again.

CAUTION: The heatsink can get hot enough to cause fire or burn injury when the TX to RX ration goes lower than 1:9.

2.5 Simplex/Duplex Channel Use

Refer to the VHF Marine Channel Chart in the Appendix for instructions on use of simplex and duplex channels.

Note: All channels are factory-programmed in accordance with FCC (USA), Industry Canada (Canada), and International regulations. Mode of operation cannot be altered from simplex to duplex or vice-versa.

2.6 International, Canada, and USA Mode

To change the channel Group call from International to Canada or USA:

1. Press and hold down the **CALL/MENU** key until the [Setup Menu] appears.
2. Rotate the **CH** knob to select [CH Function Setup] then press the [SELECT] soft key.
3. Rotate the **CH** knob to select [CH Group] then press the [SELECT] soft key.



4. Rotate the **CH** knob to select a channel Group [USA], [INTL], or [CAN (CANADA)] then press the [ENT] soft key to store the selected setting.

Note: When in INTL channel group, inland waterways channel group can be selected from the ATIS menu by switching ATIS to ON. See section 6.2.

5. Press the [QUIT] soft key several times to return to radio operation.

2.7 Backlight Adjustment

Adjust the display illumination for viewing in sunlight or darkness.

1. Press the **FUNC** key followed by the **4/DIM** key to show the [Dimmer] menu.
2. Rotate the **CH** knob to select the desired level. When [OFF] is selected, the backlight is turned off.
3. Press the [ENT] soft key to store the selected level, and return to radio operation.



2.8 NOAA Weather Channels

1. To receive a NOAA (National Oceanographic and Atmospheric Administration) weather channel, press and hold the **CLR/WX** key for two seconds on any channel. The transceiver chooses the last selected weather channel.
2. Rotate the **CH** knob to select a different NOAA weather channel.
3. To exit from the NOAA weather channels, press and hold the **CLR/WX** key. The transceiver returns to the channel in use before the weather channel.

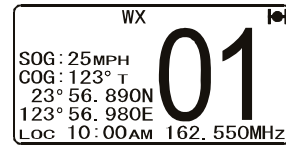

2.8.1 NOAA weather alert

In the event of extreme weather disturbances, such as storms and hurricanes, the NOAA sends a weather alert accompanied by a 1050 Hz tone and subsequent weather report on one of the NOAA weather channels. When the Weather Alert feature is enabled (see section 5.6 "Weather Alert Setup"), the transceiver is capable of receiving this alert by doing the following:

1. Program NOAA weather channels into the transceiver's memory for scanning. Follow the same procedure as for regular channels under paragraph 2.10.3 "Memory scanning (M-SCAN)".
2. Press the **FUNC** key followed by the **3/SCAN** key to start memory scanning.
3. The programmed NOAA weather channels are scanned along with the regular-programmed channels. However, scanning does not stop on a normal weather broadcast unless a NOAA alert is received.
4. When an alert is received on a NOAA weather channel, scanning stops and the transceiver emits a loud beep to alert the user of a NOAA broadcast.
5. Press the **CLR/WX** key to stop the alert and receive the weather report.

Note 1: If the **CLR/WX** key is not pressed the alert sounds for five minutes and then the weather report is received.

Note 2: While listening to a weather channel, the radio can decode a weather alert and sound an alarm.

2.8.2 NOAA weather alert test

NOAA tests the alert system every Wednesday between 11AM and 1PM UTC time. To test the FM-4721's NOAA weather feature (at the above-mentioned time) follow the procedure in paragraph 2.8.1 "NOAA weather alert" and confirm that the alert sounds.

2.9 Dual Watch (To CH16)

Dual watch scans two channels for communications. One channel is a normal VHF channel and the other is CH16. When a signal is received on the normal channel, the radio briefly switches between the normal channel and CH16 to look for a transmission. If the radio receives communications on CH16, the radio stops and listens to CH16 until communication ends and then starts dual watch scan again.

1. Adjust the **SQL** knob until the background noise just disappears.
2. Select the channel you wish to dual watch with CH16.
3. Press the **FUNC** key followed by the **6/DW** key.
The display alternately scans between CH16 and the channel that was selected in step 2.
If a transmission is received on the channel selected in step 2, the FM-4721 starts dual watch on CH16.

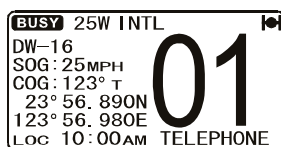

4. To stop dual watch, press the **FUNC** key followed by the **6/DW** key.

Note: The priority channel may be changed from CH16 to another channel. Refer to section 5.5 "Priority CH".

2.10 Scanning

Allows the user to select the scan type: Memory scan or Priority scan. [Memory Scan] scans the channels that were programmed into memory. [Priority Scan] scans the channels programmed in memory with the priority channel.

2.10.1 How to select the scan type

1. Press and hold down the **CALL/MENU** key until the [Setup Menu] appears.
2. Rotate the **CH** knob to select [CH Function Setup] then press the [SELECT] soft key.
3. Select [Scan Type] with the **CH** knob then press the [SELECT] soft key.
4. Rotate the **CH** knob to select [Priority Scan] or [Memory Scan] then press the [ENT] soft key to store the selected scan type.
5. Press the [QUIT] soft key several times to return to radio operation.

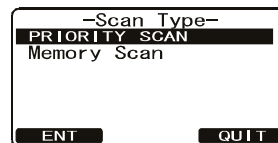
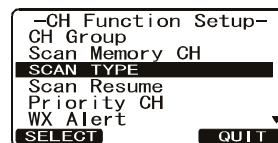
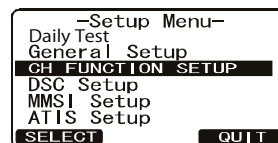

2.10.2 How to program the scan memory

1. Press and hold down the **CALL/MENU** key until the [Setup Menu] appears.
2. Rotate the **CH** knob to select [CH Function Setup].
3. Press the [SELECT] soft key, then rotate the **CH** knob to select [Scan Memory CH] then press the [SELECT] soft key.
4. Rotate the **CH** knob to select a desired channel to be scanned, then press the [ADD] soft key. [MEM] icon appears on the display, which indicates the channel has been programmed to the scan channel.
5. Repeat step 4 for all the desired channels to be scanned.
6. To delete a channel from the list, select the channel then press the [DELETE] soft key. "MEM" disappears from the display.
7. When you have completed your selection, press the [QUIT] soft key several times to return to radio operation.

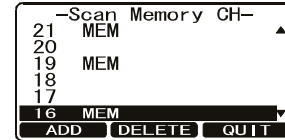

Note: You may add/delete the current channel to/from the scan list by pressing the **FUNC** key followed by the **2/MEM** key.

2.10.3 Memory scanning (M-SCAN)

1. Adjust the **SQL** knob until background noise just disappears.
2. Press the **FUNC** key followed by the **3/SCAN** key. "M-SCAN" appears on the display. Scanning starts from the lowest to the highest programmed channels and preset channels (described in the next section) and stops on a channel when a transmission is received.
3. The channel number blinks during scanning.
4. To stop scanning, press the **16/9** or **CLR/WX** key, or the **FUNC** key followed by the **3/SCAN** key.

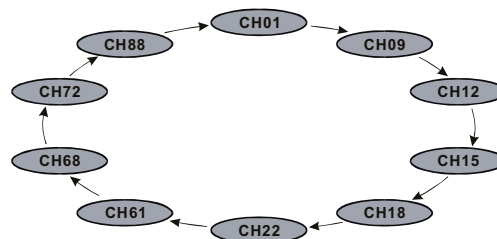
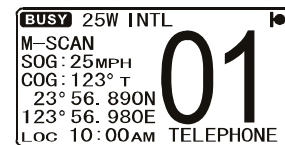

2.1 .4 Priority scanning P-SCAN

In the default setting, CH16 is set as the priority channel. (See section 5.5 for how to set priority channel.) You may change the priority channel from 16 to another channel as shown below.

1. Adjust the **S L** knob until background noise disappears.
2. Press the **NC** key followed by the **3/SCAN** key. **P-SCAN** appears on the display. Scanning starts between the memorized channels and preset channels (described in next section) and the priority channel. The priority channel is scanned after each programmed channel.
3. To stop scanning, press the **16/9** or **CLR/** key, or the **NC** key followed by the **3/SCAN** key.

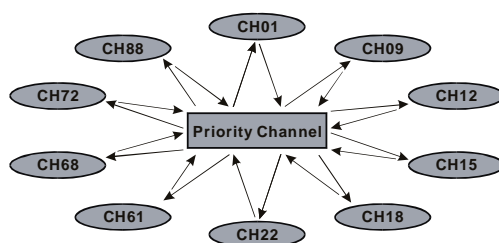
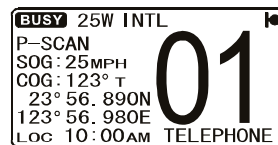

2.11 How to Preset Channels -7 : Instant Access

Eight preset channels can be programmed for instant access. Press one of the soft keys then press the **PRESET** soft key to activate the user assigned channel bank.

Before beginning the instant access operation, assign the **PRESET** command into the one of the programmable keys. See section 4.12 Soft keys.

2.11.1 How to preset channels

1. Rotate the **CH** knob to select the channel to be programmed.
2. Press one of the soft keys momentarily then press and hold the **PRESET** soft key until the channel number blinks.
3. Rotate the **CH** knob to select the desired preset channel (**SET 0** - **SET 7**) you wish to program. When you recall a preset channel (for example, **SET 1**) that is already programmed, the operating channel number (for example, 6) is shown to the right of the preset channel number.
4. Press the **ADD** soft key momentarily to program the channel into the preset channel.
5. Repeat steps 1 through 4 to program the desired channels into preset channels 0 to 7.

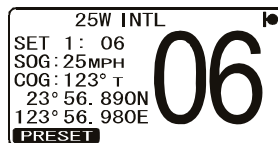
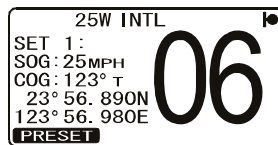
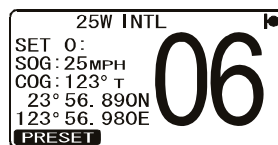

2.11.2 How to activate preset channels

1. Press one of the soft keys momentarily then press the PRESET soft key to recall the preset channel. The indication P SET above the channel number.
2. Rotate the CH knob to select the desired preset channel (0 to 7). The preset channel number appears (P SET0 - P SET7) while selecting the preset channel.
3. Press one of the soft keys momentarily then press the PRESET soft key again to return to the last selected regular channel. The indication P SET disappears from the display.

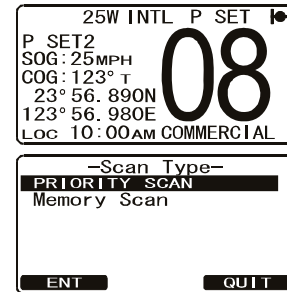

2.11.3 How to delete preset channels

1. Recall the preset channel as directed in paragraph 2.11.2.
2. Rotate the CH knob to select the preset channel to delete.
3. Press one of the soft keys momentarily. Press and hold the PRESET soft key until the indication SET(0-7) and the channel number flash.
4. Press the DELETE soft key.

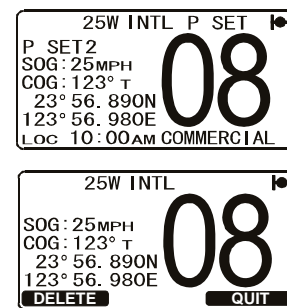

2.12 PA HAIL, HORN operation

The FM-4721 has a 30 W loudhailer that can be used with any 4-ohm PA horn. F - R NO offers a small and a large PA HAIL horn, the 220S and 240S, respectively. In the PA HAIL mode, the PA speaker listens back (acts as a microphone and sends sound to the front panel speaker and the speaker microphone) through the PA horn, which provides two-way communications through the PA horn.

PA HAIL mode: Allows the transceiver to be used as a loudhailer when an optional speaker is installed. The PA HAIL mode has a listen-back feature that provides two-way communication through the PA HAIL Speaker.

HORN mode: Selected signal (see page 2-13) is transmitted through the PA HAIL speaker. When the Fog horn, bells or whistle signal is not being outputted the FM-4721 listens back through the connected PA horn.

Note: In the PA HAIL or FOG HORN mode, the FM-4721 receives communications on the last-selected VHF channel before entering into the PA HAIL or FOG HORN mode and receive DSC calls.

2.12.1 PA HAIL mode

1. Press the **NC** key followed by the **/PA** key to activate the PA Hail mode. The indication PA appears on the display.
2. Press the **PTT** switch to speak through the HAIL /PA speaker.

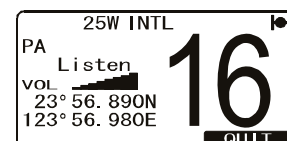

2. OPERATION

3. Rotate the **CH** knob to control the AF output level. The AF output level can be set from 0 to 30 watts.
4. Rotate the **VOL** knob to adjust the listenback volume.
5. To exit the PA HAIL mode, press the [QUIT] soft key or **CLR/WX** key.

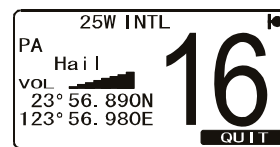

2.12.2 FOG HORN mode

There are eight signals to select from: [Underway], [Stop], [Sail], [Tow], [Aground], [Anchor], [Horn], and [Siren].

1. Press the **FUNC** key followed by the **9/FOG** key.
2. Rotate the **CH** knob to select one of the eight functions described above. (For the timing specification for each signal, see the International Regulations for Preventing Collisions at Sea.)
3. Press the [ENT] soft key.
4. On the [Horn] and [Siren] modes, press the **PTT** switch to activate the tone through the HAIL/PA speaker. Rotate the **CH** knob to control the AF output level, which can be set from 0 to 30 watts.
5. If the fog signal is not output, rotate the **VOL** knob to adjust the listenback volume.
6. To exit the FOG HORN mode, press the [QUIT] soft key or **CLR/WX** key.

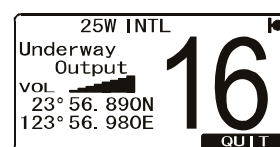

FOG HORN timing chart

Type	Pattern	Usage
[Underway]	One 5-second blast every 120 seconds.	Motor vessel underway and making way.
[Stop]	Two 5-second blasts (separated by 2 seconds) every 120 seconds.	Motor vessel underway but stopped (not making way).
[Sail]	One 5-second blast followed by two 1-second blasts (separated by 2 seconds) every 120 seconds.	Sailing vessel underway, fishing vessel (underway or anchored), vessel not under command, a vessel restricted in her ability to maneuver (underway or at anchor), or a vessel towing or pushing another ahead.
[Tow]	One 5-second blast followed by three 1-second blasts (separated by 2 seconds) every 120 seconds.	Vessel is being towed (manned).
[Aground]	One 11-second ring every 60 seconds.	Vessel is aground.
[Anchor]	One 5-second ring every 60 seconds.	Vessel is at anchor.
[Horn]	Varying pitch (yelp) tone while pressing the PTT switch.	
[Siren]	Passing signal while the PTT switch is pressed.	

2.13 Intercom Operation

The intercom function is available if your radiotelephone is equipped with two HS-4721 Handsets.

2.13.1 Communication

1. Press the **FUNC** key followed by the **5/IC** key to enable the intercom mode.
2. Use the **CH** knob to select the intercom to use ([RAM1], [RAM2], or [ALL]), then press the **ENT** key. When the intercom mode is enabled, "Intercom" is displayed on the radio and the HS-4721.

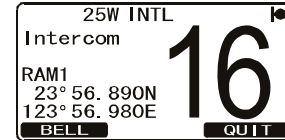

3. Press the **PTT** switch on the radio. [Talk] appears on the display.

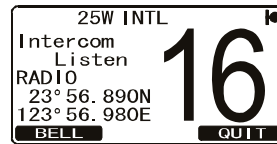
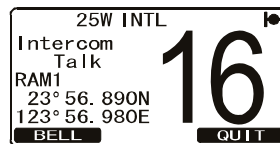

FM-4721's PTT switch is pressed

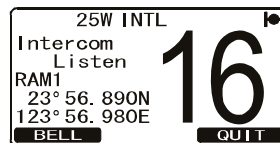

HS-4721's PTT switch is pressed

Note: A warning beep sounds when the radio's **PTT** and the Handsets' **PTT** are pushed at the same time.

4. Speak slowly and clearly into the microphone. Hold the microphone about 1.5 cm away from your mouth.
5. When finished, release the **PTT** switch.
6. Press the [QUIT] soft key or the **CLR/WX** key to exit the intercom mode and revert to the radio mode.

2.13.2 How to call on the Intercom

Press the [BELL] soft key on either the radio or a Handset to generate a calling beep at the station called.

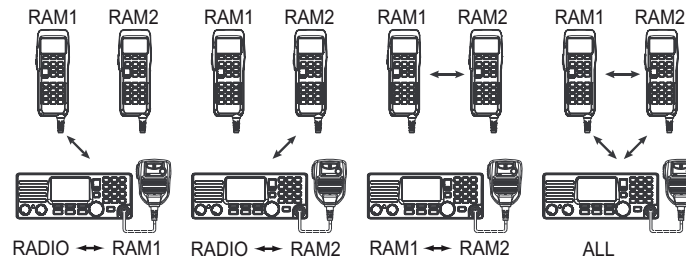

2.14 Bluetooth Operation (option)

Installation of the optional BU-1 Bluetooth Adapter Unit enables the FM-4721 to send/receive voice messages with a BH-2A Bluetooth Headset via wireless links. When the BH-2A is connected, [Bluetooth] appears in the [General Setup Menu].

2.14.1 Pairing

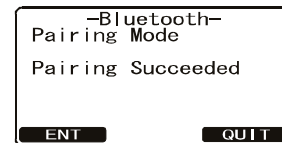
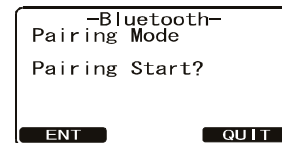
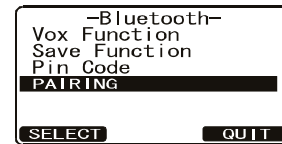
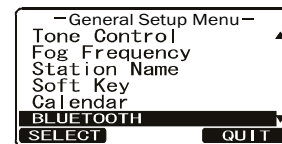
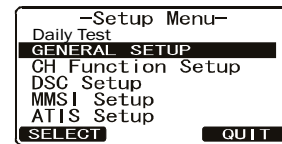

Before you use the BH-2A Bluetooth Headset, pair the BH-2A Bluetooth Headset and the FM-4721 as follows:

1. Press and hold down the **CALL/MENU** key until the [Setup Menu] appears.
2. Rotate the **CH** knob to select [General Setup] then press the [SELECT] soft key.
3. Rotate the **CH** knob to select [Bluetooth] then press the [SELECT] soft key.
4. Rotate the **CH** knob to select [PAIRING] then press the [SELECT] soft key.
5. Bring the BH-2A Bluetooth Headset close to the FM-4721, then press and hold the **POWER** switch on the BH-2A until the LED indicator blinks red and blue alternately.
6. Press the [ENT] soft key to initiate the pairing.
7. When the BH-2A is correctly recognized (approx. 20 to 30 seconds) by the FM-4721, the BH-2A's LED indicator blinks blue, and "Pairing Succeeded" appears on the display of the FM-4721.
8. Press the [QUIT] soft key several times to exit this menu and return to radio mode.



Note: When the BH-2A is correctly recognized by the FM-4721, the  icon appears at the top right corner on the display.

2.14.2 Operation

1. When the BH-2A is correctly recognized by the FM-4721,  icon appears on the display of the FM-4721 and the LED indicator of the BH-2A blinks blue.
2. Adjust the receiver audio level using the **VOLUME(+)**/**VOLUME(-)** switches on the BH-2A.
3. Press the **PTT** switch on the BH-2A to transmit. Release the **PTT** switch to return to receive.
4. The communication range between the BH-2A and FM-4721 is around 7 m (21 ft). If you move out of range, a beep sounds from the BH-2A to alert you. If you move back into range, the BH-2A beeps to alert you that you are back within range.
5. When the battery voltage of the BH-2A is low, the following occurs:
 - a) The LED blinks red and blue alternately.
 - b) A beep sounds from the BH-2A.
 - c) The  icon on the FM-4721 blinks rapidly.

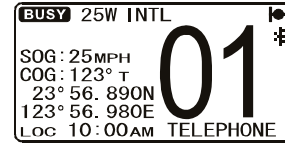

Charge the BH-2A battery with the CD-40 Charger Cradle.

2.14.3 VOX feature

The VOX (Voice Operation Transmission) feature provides automatic transmit/receive switching based on voice input to the microphone. With the VOX feature enabled, you do not need to press the **PTT** switch in order to transmit, and it is not necessary to use a VOX headset in order to utilize VOX operation.

1. Press and hold down the **CALL/MENU** key until the [Setup Menu] appears.
2. Rotate the **CH** knob to select [General Setup] then press the [SELECT] soft key.
3. Rotate the **CH** knob to select [Bluetooth] then press the [SELECT] soft key.
4. Rotate the **CH** knob to select [VOX FUNCTION] then press the [SELECT] soft key. Rotate the **CH** knob to select the desired VOX function then press the [ENT] soft key.
 - [Off]: Disable the VOX feature.
 - [High]: Activate the VOX feature (VOX gain: High).
 - [Low]: Activate the VOX feature (VOX gain: Low).
5. Press the [QUIT] soft key several times to exit this menu and return to radio mode.

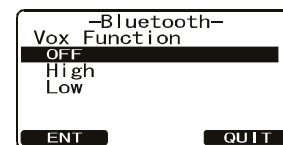

2.14.4 Battery saver

Enable/Disable the battery saver of the optional BH-2A Bluetooth Headset.

1. Press and hold down the **CALL/MENU** key until the [Setup Menu] appears.
2. Rotate the **CH** knob to select [General Setup] then press the [SELECT] soft key.
3. Rotate the **CH** knob to select [Bluetooth] then press the [SELECT] soft key.
4. Rotate the **CH** knob to select [Save Function] then press the [SELECT] soft key.
5. Select [On] or [Off] then press the [ENT] soft key.
Press the [QUIT] soft key several times to exit this menu and return to radio operation.

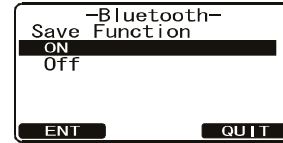

[On]: Activates the Battery Saver in the BH-2A. If there is no signal or key activity for 20 seconds, the Battery Saver automatically puts the BH-2A to sleep, to conserve battery life. When a signal is received or the **PTT** switch is pressed, the BH-2A becomes active. Furthermore, if there is no signal or key activity for 10 minutes, the BH-2A turns off automatically.

[Off]: Disables the Battery Saver in the BH-2A.

2.15 Voice Scrambler (option)

The optional Voice Scrambler FVP-42 is a 32-code voice scrambler (VS) that installs in the transceiver, and provides private communications with other FM-4721 equipped with the FVP-42. Contact your dealer to have a FVP-42 installed.

1. Rotate the **CH** knob to select the channel to scramble.
Note: CH16 and 70 can not operate the voice scrambler.
2. Press the **FUNC** key then press and hold down the **7/SQRM** key until the [Scrambler] menu appears.
3. Rotate the **CH** knob to set the desired scrambler code. The scrambler code can be set from 0 to 31.
4. Press the [ENT] soft key to save the scrambler code and return to the radio mode. "VS" and scrambler number (0 - 31) appear on the display.
5. Press the **FUNC** key followed by the **7/SQRM** key to activate the voice scrambler.
6. Monitor the channel before transmitting.
7. To disable the voice scrambler, press the **FUNC** key followed by the **7/SQRM** key again. VS and scrambler number disappear from the display.

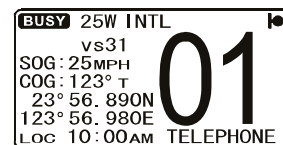
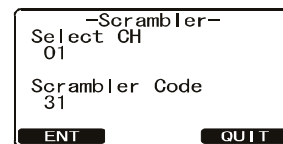
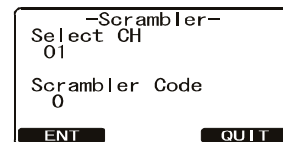
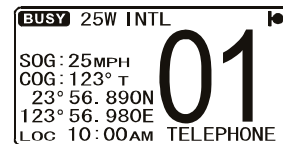

3. DIGITAL SELECTIVE CALLING

3.1 General

NOTICE

This radio is designed to generate a digital maritime distress and safety call to facilitate search and rescue. To be effective as a safety device, this equipment must be used only within communication range of a shore-based VHF marine channel 70 distress and safety watch system. The range of the signal may vary, but under normal conditions it should be approximately 20 nautical miles.

Digital Selective Calling (hereafter abbreviated as DSC) is a semi-automated method of establishing a radio call. DSC has been designated by the International Maritime Organization (IMO) as an international standard for establishing VHF, MF and HF radio calls. It has also been designated as a part of the Global Maritime Distress and Safety System (GMDSS). DSC replaces aural watches on distress frequencies and announces routine and urgent maritime safety information broadcasts.

This system allows mariners to instantly transmit a distress call with GPS position to the Coast Guard and other vessels within range of the transmission. DSC also allows mariners to initiate or receive distress, urgency, safety, routine, position request, position transmit and group calls to or from another vessel equipped with a DSC transceiver.

3.2 Maritime Mobile Service Identity (MMSI)

3.2.1 What is an MMSI?

An MMSI is a nine-digit number used on marine transceivers capable of using DSC. This number is used like a telephone number to selectively call other vessels.

Note: This vessel's MMSI must be entered into the radio to use the DSC functions.

3.2.2 How to enter your MMSI number

NOTICE

An MMSI can be entered only once. Therefore, be careful not to enter the wrong MMSI number. If you need to change the MMSI number after it has been entered, return the radio to the factory.

3. DIGITAL SELECTIVE CALLING

1. Press and hold down the **CALL/MENU** key until the [Setup Menu] appears.
2. Rotate the **CH** knob to select [MMSI Setup] then press the [SELECT] soft key.
3. Enter your MMSI number (nine digits) by the numeric keys (**0** to **9/FOG** key). If you enter a wrong digit, press the [BACK] soft key until the wrong digit is selected then press the correct numeric key.
4. After you have entered the MMSI number, press and hold the [ENT] soft key. The message "Input Again" appears.
5. Enter the MMSI number again then press and hold the [ENT] soft key again to save the MMSI number.
6. Press the [OK] soft key to return to radio operation.

Note: To view your MMSI number, to ensure it is correct, do steps 1 to 2.

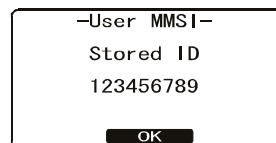
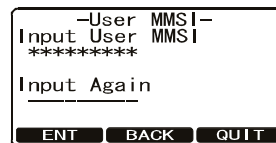
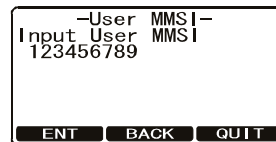
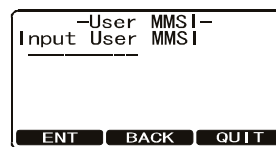

3.3 DSC Distress Alert

The FM-4721 is capable of transmitting and receiving DSC distress alerts. The FM-4721 may be connected to a GPS receiver to also transmit the latitude and longitude position of the vessel together with the DSC distress alert.

3.3.1 How to transmit a DSC Distress Alert

Note: To transmit a DSC Distress Alert, an MMSI number must be registered in the transceiver. Refer to section 3.2.2 for how to enter your MMSI number.

How to transmit a DSC Distress Alert without specifying nature of distress

1. Lift the red spring-loaded DISTRESS cover.
2. Press and hold the **DISTRESS** key (approx. 3 seconds). The unit beeps and the display counts down the time remaining until the distress alert is sent. The backlight of the display and numeric keys flash while the display counts down the time remaining.
3. After the distress signal is sent, the transceiver watches for a transmission between CH16 and CH70 until an acknowledgment signal is received. The display shows "Waiting for ACK" while the equipment waits for acknowledgement.
4. If no acknowledgment is received, the distress alert is repeated in 3.5 - 4.5-minute intervals, until a DSC acknowledgment is received.

Note: To turn off the distress alarm until the radio retransmits the distress call, press the **16/9** key.

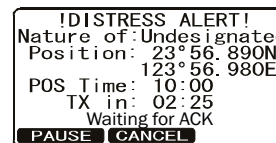
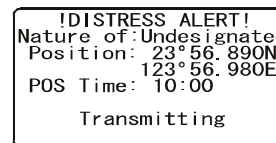
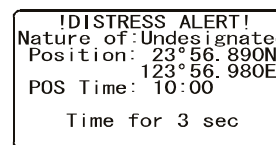

5. When you receive the DSC distress acknowledgment, a distress alarm sounds and CH16 is automatically selected. The display shows the MMSI of the ship responding to your distress and the applicable acknowledgment message.

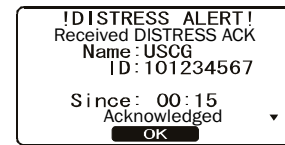

"Received DISTRESS ACK": Acknowledgment signal is received.

"Received RELAY ACK": Relay acknowledgment signal is received from another vessel or coast station.

6. Press the **PTT** switch and state your name, vessel name, number of persons on board and the distress situation, then say over. Wait for a reply from the acknowledging ship.
7. To conclude both voice communications and the distress alert sequence, press the [OK] soft key.

How to transmit a DSC Distress Alert with nature of distress specified

The FM-4721 is capable of transmitting a DSC Distress Alert with the following "Nature of Distress" categories: Undesignated, Fire, Flooding, Collision, Grounding, Capsizing, Sinking, Adrift, Abandoning, Piracy, and MOB (Man Overboard).

1. Press the **CALL/MENU** key to show the [DSC Menu].
2. Rotate the **CH** knob to select [Distress Alert MSG] then press the [SELECT] soft key.

3. Press the [NATURE] soft key to show the [!NATURE OF!] menu.

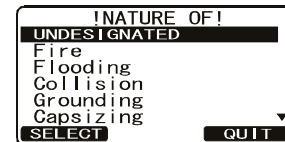

4. Rotate the **CH** knob to select the desired nature of distress category then press the [SELECT] soft key. For example, select Fire.

5. Lift the red spring-loaded DISTRESS cover.
6. Press and hold the **DISTRESS** key (approx. 3 seconds). The unit beeps and the display counts down the time remaining until the distress alert is sent. The backlight of the display and numeric keys flash while the display counts down the time remaining.

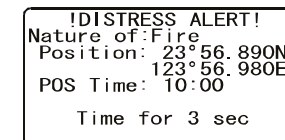

7. When the distress signal is sent, the transceiver watches for a transmission between CH16 and CH70 until an acknowledgment signal is received. The display shows "Waiting for ACK" while the equipment waits for acknowledgement. If no acknowledgment is received, the DSC Distress Alert call is repeated in 3.5 - 4.5-minute intervals until an acknowledgment is received.

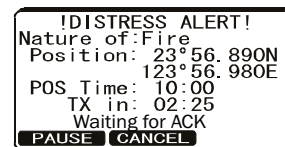

Note: To turn off the distress alarm until the radio retransmits the distress call, press the **16/9** key.

8. When you receive the DSC distress acknowledgment, a distress alarm sounds and CH16 is automatically selected. The display shows the MMSI of the ship responding to your distress and the applicable acknowledgment message.

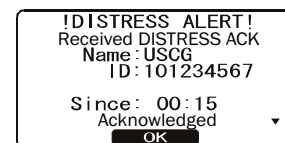

"Received DISTRESS ACK": Acknowledgment signal is received.

Received RE A AC : Relay acknowledgment signal is received from another vessel or coast station.

9. Press the **PTT** switch and state your name, vessel name, number of persons on board and the distress situation, then say over. Wait for a reply from the acknowledging ship.
10. To conclude both voice communications and the distress alert sequence, press the **O** soft key.

How to transmit a DSC Distress Alert with manual position input

If no position data is available at the time of distress, insert the latitude and longitude position of your vessel manually in the DSC Distress Alert.

1. Press the **CALL/M N** key to show the DSC Menu .
2. Rotate the **CH** knob to select Distress Alert MS then press the **SELECT** soft key.
3. Press the **POS/TM** soft key.
4. Enter the latitude and longitude of your vessel and your local time in 24-hour notation, using the numeric keys (to **9/** key).
To select North (N) press the **6/D** key, South (S) press the **7/S RM** key, East (E) press the **3/SCAN** key, or West (W) press the **9/** key. You may back-space the cursor by pressing the **AC** soft key.

5. Press and hold the **ENT** soft key for two seconds to save the position entered.
6. Lift the red spring-loaded **DISTRESS** cover.
7. Press and hold the **D STR SS** key (approx. 3 seconds). The unit beeps and the display counts down the time remaining until the distress alert is sent. The backlight of the display and numeric keys flash while the display counts down the time remaining.

When the distress signal is sent, the transceiver watches for a transmission between CH16 and CH70 until an acknowledgment signal is received. The display shows waiting for AC while the equipment waits for acknowledgement. If no acknowledgment is received, the distress call is repeated in 3.5 - 4.5-minute intervals until an acknowledgment is received.

Note: To turn off the distress alarm until the radio retransmits the distress call, press the **16/9** key.

9. When you receive the DSC distress acknowledgment, a distress alarm sounds and CH16 is automatically selected. The display shows the MMSI of the ship responding to your distress and the applicable acknowledgement message.

Received **DISTRESS AC** : Acknowledgment signal is received.

Received **RE A AC** : Relay acknowledgment signal is received from another vessel or coast station.

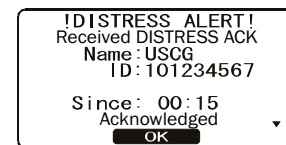
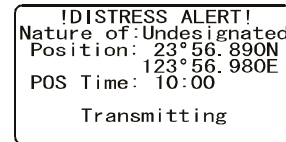
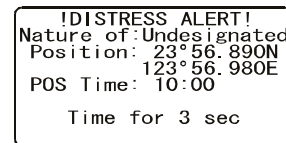
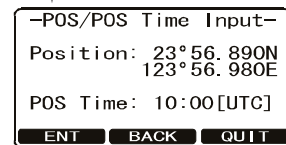
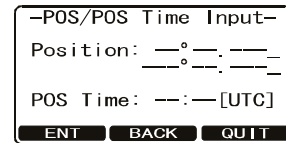
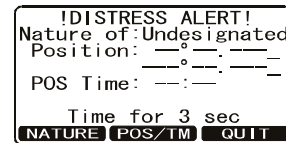

- Press the **PTT** switch and state your name, vessel name, number of persons on board and the distress situation, then say over. Wait for a reply from the acknowledging ship.
- To conclude both voice communications and the distress alert sequence, press the **O** soft key.

How to pause a DSC Distress Alert

After a DSC Distress Alert is transmitted, the DSC Distress Alert is repeated in 3.5 - 4.5-minute intervals until the call is canceled by the user or until the radio is turned on and off again. The FM-4721 has a provision to suspend (Pause) the retransmitting of the distress call.

- After the distress alert is transmitted, the radio shows the topmost display at right.
Time: 02:25 is the time remaining until the radio retransmits the DSC Distress Alert.
- To suspend re-transmitting the DSC Distress Alert, press the **PAUSE** soft key.
- To resume counting down to transmit the DSC Distress Alert, press the **RESUME** soft key.

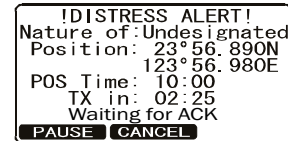
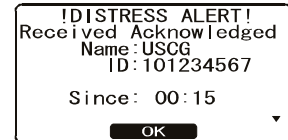
How to cancel a DSC Distress Alert

If you sent a DSC Distress Alert unintentionally, you must transmit a message to other vessels to cancel that distress alert. Press the **CANCEL** soft key then press **YES** soft key.

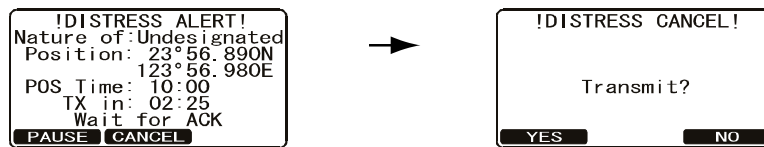

3.3.2 How to receive a DSC Distress Alert

- When a DSC Distress Alert is received, the emergency alarm sounds. Press any key to stop the alarm.
- The display shows the position of the vessel in distress. To show additional information of the vessel in distress, rotate the **CH** knob clockwise (refer to the second display).

On the display, you should see three soft keys.

ACCEPT : Accept the DSC Distress Alert call and switch to CH16.

PAUSE : Temporarily disable automatic switching to CH16.

QUIT : Quit the automatic switching to CH16 and revert to the last selected working channel.

Note 1: If no key is pressed within 10 seconds, the radio automatically selects CH16.

Note 2: You must continue to monitor CH16, as a coast station may require assistance in the rescue attempt.

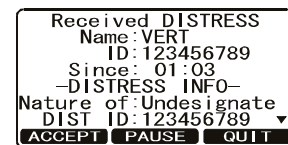

CH

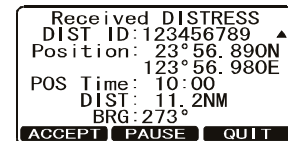

3.4 All Ships Call

The All Ships call function establishes contact with DSC-equipped vessels without having their MMSI in the directory. Also, priority for the call can be designated as urgency or safety.

rgency Call: This type of call is used when a vessel may not truly be in distress, but has a potential problem that may lead to a distress situation. This call is the same as saying Pan-Pan-Pan on CH16.

Safety Call: Used to transmit boating safety information to other vessels. This message usually contains information about an overdue boat, debris in the water, loss of a navigation aid, or an important meteorological message. This call is the same as saying Securite, Securite, Securite.

3.4.1 How to transmit an All Ships call

1. Press the **CALL/M N** key to show the DSC Menu.
 2. Rotate the **CH** knob to select All Ships then press the **SE ECT** soft key.
 3. Rotate the **CH** knob to select the nature of call (Safety or rgency), then press the **SE ECT** soft key.
 4. Rotate the **CH** knob to select the operating channel you want to communicate on then press the **SE ECT** soft key.
 5. Press the **ES** soft key to transmit the All Ships call.
 6. After the All Ships call is transmitted, the transceiver switches to the selected channel.
 7. Listen to the channel to make sure it is not busy, then key the microphone and say Pan-Pan-Pan or Securite, Securite, Securite depending on the priority of the call.
- Press the **IT** soft key to exit the All Ships Call menu.

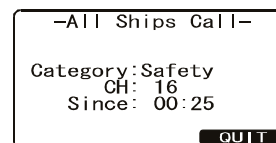
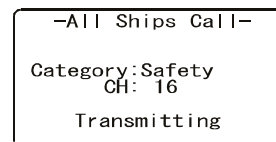
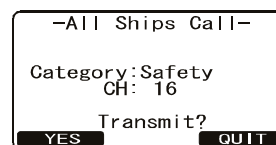
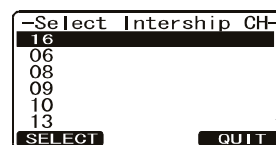
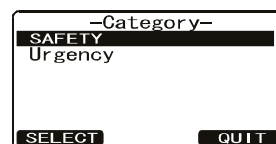

3.4.2 How to receive an All Ships call

1. When an All Ships call is received, an emergency alarm sounds. The display shows the MMSI of the vessel transmitting the All Ships call and the radio changes to the requested channel after 10 seconds.
2. Press any key to stop the alarm.
3. Monitor the requested channel until the all ships voice communication is completed.

The display shows three soft keys:

[ACCEPT]: Accept the DSC All Ship call and to switch to requested channel.

[PAUSE]: Temporarily disable automatic switching to the requested channel. (In some cases automatically switching to a requested channel might disrupt important ongoing communications. This feature allows commercial users to suspend channel switching and stay on the working channel selected before the All Ships call was received.)

[QUIT]: Quit the automatic channel switching and revert to the last selected working channel.

Note: If no key is pressed within 10 seconds the radio automatically changes to the requested channel.

4. Press the [QUIT] soft key to return to the channel display.

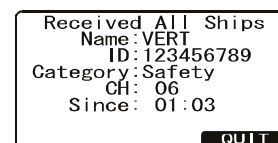
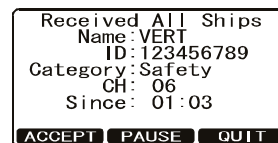

3.5 Individual Call

The Individual call contacts another vessel with a DSC VHF radio and automatically switches the receiving radio to a desired communications channel. This feature is similar to calling a vessel on CH16 and requesting to go to another channel. Up to 80 individual contacts can be programmed, in the Individual Directory.

3.5.1 How to register DSC stations to the Individual Directory

The Individual Directory allows you to save a vessel or person's name and the MMSI number associated with vessels you wish to transmit Individual calls, auto polling, position request, and position report transmissions.

To transmit an Individual call you must program this directory with information of the persons you wish to call, similar to how you program the telephone directory in a cellular phone.

1. Press and hold down the **CALL/MENU** key until the [Setup Menu] appears.
2. Rotate the **CH** knob to select the [DSC Setup] menu then press the [SELECT] soft key.
3. Select [Individual Directory] with the **CH** knob then press the [SELECT] soft key.
4. Select [ADD] with the **CH** knob then press the [SELECT] soft key.

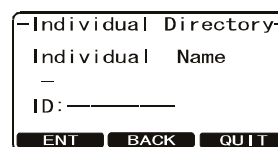
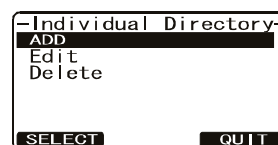

3. DIGITAL SELECTIVE CALLING

5. Enter the first letter of the name of the vessel or person you want to reference in the directory.
Example: Press the **8/PA** key repeatedly to toggle among the seven available characters associated with that key: 8 → T → U → V → t → u → v → 8...
6. Press the [ENT] soft key to save the first letter in the name and move to the next letter to the right.
7. Repeat steps 5 and 6 to complete the name. The name can have a maximum of 11 characters. Use the [ENT] soft key to move to the next space. This method can also be used to enter a blank space in the name. If you enter a wrong character, press the [BACK] soft key until the wrong character is selected, then enter the correct character.
8. After the eleventh letter or space has been entered, press and hold the [ENT] soft key to advance to the ID line, where you enter the MMSI number.
9. Enter the MMSI number (nine digits). If you enter a wrong digit, press the [BACK] soft key until the wrong digit is selected, then press the correct numeric key.
10. After you have entered the MMSI number, press and hold the [ENT] soft key to save the data.
11. Press the [QUIT] soft key several times to return to radio operation.

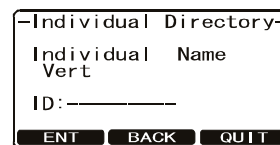

3.5.2 How to select the Individual call reply method

The DSC Individual call requests you to switch to a working channel for voice communications. The radio can automatically or manually switch to the channel. For manual, the default setting, the MMSI of the calling vessel is shown, allowing you to see who is calling. This function is similar to the caller ID feature on a cellular phone.

1. Press and hold down the **CALL/MENU** key until the [Setup Menu] appears.
2. Rotate the **CH** knob to select [DSC Setup] menu then press the [SELECT] soft key.
3. Select [Individual Reply] with the **CH** knob then press the [SELECT] soft key.
4. Rotate the **CH** knob to select [Automatic] or [Manual] then press the [ENT] soft key to save the setting.
5. Press the [QUIT] soft key several times to return to radio operation.

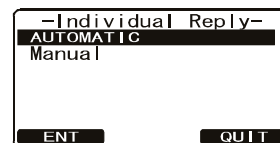

3.5.3 How to select the Individual call acknowledge method

The radio can be setup to transmit a reply automatically (default setting) or set so the radio does not reply to an Individual call.

1. Press and hold down the **CALL/MENU** key until the [Setup Menu] appears.
2. Rotate the **CH** knob to select [DSC Setup] menu then press the [SELECT] soft key.
3. Select [Individual Ack] with the **CH** knob then press the [SELECT] soft key.
4. Rotate the **CH** knob to select [Able to Comply] or [Unable] then press the [ENT] soft key to save the selected setting.
5. Press the [QUIT] soft key several times to return to radio operation.

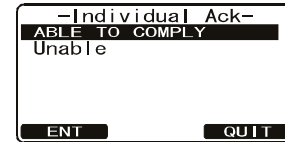

3.5.4 Individual/Group call ringer

When an Individual call or Group call is received, the radio produces a ringing sound for two minutes (default setting). You can select the Individual call ringer time and turn the ringer on or off as desired.

How to set the individual/Group call ringer time

1. Press and hold down the **CALL/MENU** key until the [Setup Menu] appears.
2. Rotate the **CH** knob to select [DSC Setup] menu then press the [SELECT] soft key.
3. Select [Individual Ring] with the **CH** knob then press the [SELECT] soft key.
4. Rotate the **CH** knob to select a ringing time then press the [ENT] soft key to save the setting.
5. Press the [QUIT] soft key several times to return to radio operation.

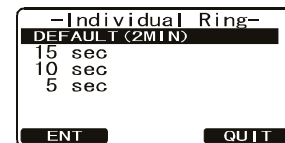

How to turn the ringer off

1. Press and hold down the **CALL/MENU** key until the [Setup Menu] appears.
2. Rotate the **CH** knob to select [DSC Setup] menu then press the [SELECT] soft key.
3. Select [DSC Beep] with the **CH** knob then press the [SELECT] soft key.
4. Rotate the **CH** knob to select [Individual] if you wish to disable the Individual call ringer, or [Group] if you wish to disable the Group call ringer.
5. Press the [ENT] soft key
6. Rotate the **CH** knob to select [Off] then press the [ENT] soft key to save the setting.
7. Press the [QUIT] soft key several times to return to radio operation.

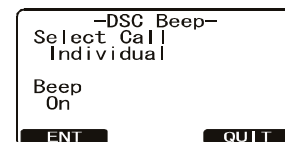

To turn the ringer on, select [On] at step 6 in the procedure.

3. . How to transmit an ndi id al call

The Individual call lets you contact a vessel that has a DSC radio. This feature is similar to calling a vessel on CH16 and requesting to go to another channel.

Transmit to vessel registered in the ndi id al Directory

1. Press the **CALL/M N** key to show the DSC Menu .
2. Rotate the **CH** knob to select Individual then press the **SE ECT** soft key.
3. Rotate the **CH** knob to select who you want to contact then press the **SE ECT** soft key.
4. Rotate the **CH** knob to select the operating channel you want to communicate on, then press the **SE ECT** soft key.
5. Press the **ES** soft key to transmit the individual DSC signal.
6. When an Individual call acknowledgment is received, the established channel is automatically changed to the channel which is selected at step 4 above and a ringing tone sounds.
7. Press the **IT** soft key to listen to the channel to make sure it is not busy, then press the microphone's **PTT** switch and talk into the microphone to the other vessel.

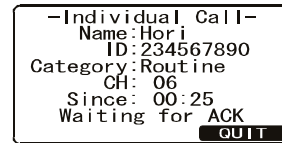
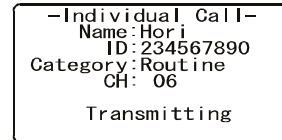
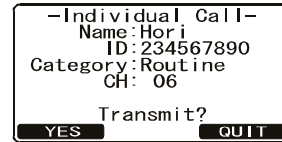
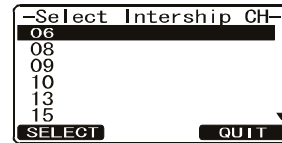

Transmit to vessel not registered in the ndi id al Directory

You can make an Individual call by using a manually entered MMSI number.

1. Press the **CALL/M N** key to show the DSC Menu .
2. Rotate the **CH** knob to select Individual then press the **SE ECT** soft key.
3. Press the **NEW ID** soft key, select **MAN A** with the **CH** knob then press the **SE ECT** soft key.
4. Enter the MMSI number (nine digits). (If you enter a wrong digit, press the **AC** soft key until the wrong digit is selected, then press the correct numeric key.)

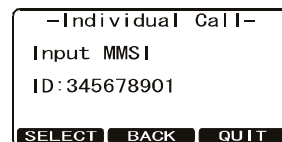
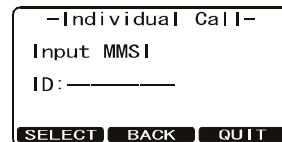
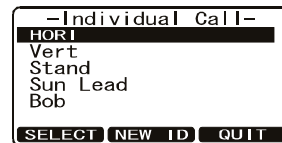

5. After you have entered the MMSI number, press and hold the SE ECT soft key.
6. Rotate the CH knob to select the operating channel you want to communicate on then press the SE ECT soft key.
7. Press the ES soft key to transmit the individual DSC signal.
 - When an Individual call acknowledgment is received, the established channel is automatically changed to the channel which is selected at step 6 above and a ringing tone sounds.
9. Press the IT soft key to listen to the channel to make sure it is not busy, then press the microphone's PTT switch and talk into the microphone to the other vessel.

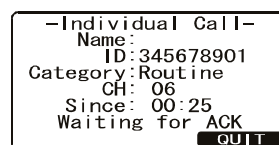
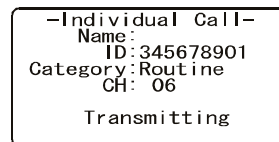
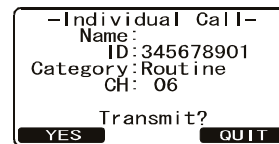
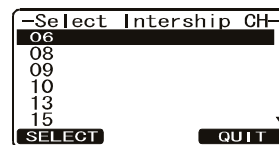

3. .6 How to receive an individual call

When an individual DSC call is received, the radio proceeds according to how it is set for individual call reply. In automatic reply, the radio automatically responds (default setting) to the calling ship and switches to the requested channel for voice communications. For manual reply, the operator selects whether to reply to the call or not.

Automatic reply

1. When an Individual call is received, the Individual call ringing alarm sounds. Push any key to stop the alarm. The radio automatically switches to the requested channel. The display shows the MMSI of the vessel calling.
2. Press any key to stop the alarm.
3. Press the IT soft key to return to radio operation.
4. Press the microphone's PTT switch and talk into the microphone to the other vessel.

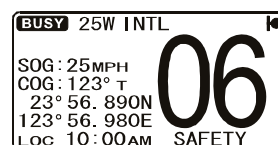
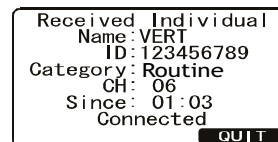

Manual reply

1. When an Individual call is received, the Individual call ringing alarm sounds.

Push any key to stop the alarm. The display shows the MMSI of the vessel calling and three soft keys: ACCEPT, PAUSE, and QUIT.

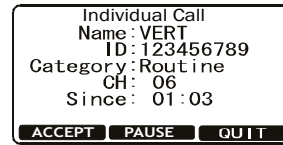



ACCEPT: Continue with the call. You can change the channel if necessary.

PAUSE: Pause the call. The radio shows the standby display with the indication INDIVIDUAL Pausing flashing. You can resume the call by pressing the RESUME soft key.

QUIT: Quit the call.

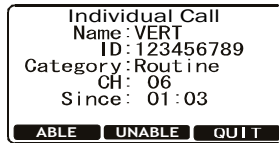
2. Press the ACCEPT soft key and the screen shown below appears. Follow the appropriate instructions in the table below.

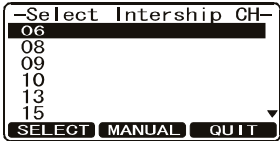

ABLE to reply	UNABLE to reply
<p>1) Press the ABLE soft key.</p>  <p>2) Do one of the following: a) Transmit on the channel selected: Press the YES soft key. Go to step 5). b) Transmit on a different channel: Press the CHG CH soft key to show the channel selection screen.</p>  <p>3) Use the CH knob to select a channel then push the SELECT soft key. For manual channel input, press the MANUAL soft key.</p> <p>4) The display shown after step 1) appears press the YES soft key to transmit.</p> <p>5) When the message Connected appears, press the microphone's PTT switch and talk into the microphone to the other vessel.</p>	<p>Press the UNABLE soft key. The standby display appears after completion of the transmission.</p>

3.6 DSC Log

The FM-4721 logs transmitted calls, received distress calls, and Individual calls. The DSC log feature is similar to an answering machine where calls are recorded for review. A  icon appears in the log to indicate unread received call. The FM-4721 can store the latest 24 transmitted calls, the latest 27 distress calls, and the latest 64 other calls ([Individual], [Group], [All Ship], etc.).

3.6.1 Transmitted call log

The transmitted call log stores all transmitted DSC calls. Calls can be made from the log.

1. Press the **CALL/MENU** key to show the [DSC Menu].
2. Rotate the **CH** knob to select [DSC Log] menu then press the [SELECT] soft key.
3. Rotate the **CH** knob to select [Transmitted Log] then press the [SELECT] soft key.
4. Rotate the **CH** knob to select the station (name or MMSI number) then press the [SELECT] soft key to review details for the selected station.
5. Press the [CALL] soft key to retransmit the call, if desired, or the [QUIT] soft key to close the log.

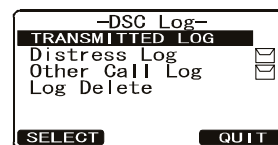

3.6.2 Distress log

1. Press the **CALL/MENU** key to show the [DSC Menu].
2. Rotate the **CH** knob to select [DSC Log] menu then press the [SELECT] soft key.
3. Rotate the **CH** knob to select [Distress Log] then press the [SELECT] soft key.
4. Rotate the **CH** knob to select the station (name or MMSI number) you want to review the distress call then press the [SELECT] soft key to show call details.
5. Press the [QUIT] soft key to close the log.

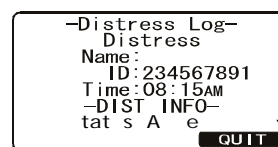

3.6.3 Other call log

1. Press the **CALL/MENU** key to show the [DSC Menu].
2. Rotate the **CH** knob to select [DSC Log] menu then press the [SELECT] soft key.
3. Rotate the **CH** knob to select [Other Call Log] then press the [SELECT] soft key.
4. Rotate the **CH** knob to select the station (name or MMSI number) you want to review and/or call back then press the [SELECT] soft key.
5. Press the [CALL] soft key to call back, if desired, or the [QUIT] soft key to close the log.

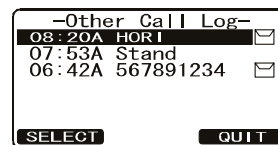

3.6.4 How to delete calls from a log

1. Press the **CALL/MENU** key to show the [DSC Menu].
2. Rotate the **CH** knob to select [DSC Log] menu then press the [SELECT] soft key.
3. Rotate the **CH** knob to select [LOG Delete] menu then press the [SELECT] soft key.
4. Rotate the **CH** knob to select the category ([Transmitted Log], [Distress Log], or [Other Call Log]) to delete then press the [SELECT] soft key. For example, select the [Distress Log].
5. Select [All Log Delete] or [View Log List] then press the [SELECT] soft key. Do one of the following:
 - **Delete all entries from selected log**
Select [All Log Delete] with the **CH** knob, press the [SELECT] soft key, then press the [OK] soft key.
 - **Delete individual log entry**
Select [View Log List] with the **CH** knob then press the [SELECT] soft key. Rotate the **CH** knob to select the station (name or MMSI number) to delete then press the [DELETE] soft key. The display shows "Are your sure?". Press the [OK] soft key.

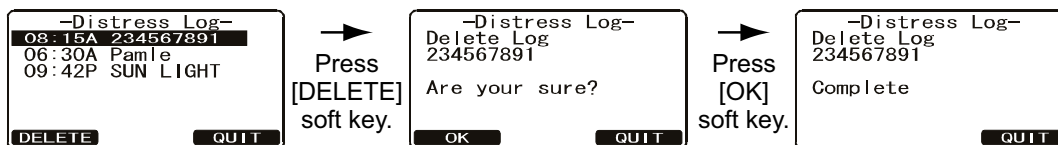
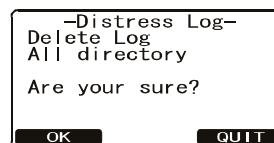
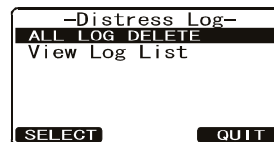

6. Press the [QUIT] soft key several times to return to radio operation.

3.7 Group Call

A Group call allows the user to contact a group of specific vessels (example members of a yacht club) using DSC radios that have a Group call function. When a Group call is sent, all DSC radios in the group automatically switch to the channel specified in the call to prepare for voice communications. This function is useful for yacht clubs and vessels traveling together that want to collectively make announcements on a pre-determined channel. Up to 32 Group call MMSIs can be programmed.

3.7.1 How to register DSC stations to the Group Directory

For this function to operate, the same Group call MMSI must be registered into all the DSC VHF radios within the group of vessels that use this feature. To understand Group call MMSI programming, first a ship MMSI has to be understood.

Ship MMSI: The first three digits are called an MID (Maritime Identification Digits) and identify the country where the ship's MMSI is registered. The last six digits are specific to the ship's ID. For example, if the MMSI is "366123456", "366" is the MID and "123456" is the ship's MMSI.

Group MMSI:

- Group MMSI numbers are not assigned by the FCC or other organizations licensed to assign ship MMSI.
- The first digit of a Group call MMSI is always set to "0" as required by international regulations. All FURUNO radios automatically have "0" as the first digit in a Group call MMSI.
- The USCG recommends programming the MID of a ship MMSI into the second, third and fourth digits of the Group call MMSI as it denotes the area the ship is located.
- The last five digits are decided by persons in the group. This is an important step as all radios in the group must contain the same Group call MMSI so they can contact one another. There is a chance that another group of vessels has the same Group call MMSI as yours. If this happens, simply change one or more of the last five digits of the Group call MMSI.

1. Press and hold down the **CALL/MENU** key until the [Setup Menu] appears.
2. Rotate the **CH** knob to select [DSC Setup] menu then press the [SELECT] soft key.
3. Select [Group Directory] with the **CH** knob then press the [SELECT] soft key.
4. Select [Add] with the **CH** knob then press the [SELECT] soft key.
5. Enter the first letter of the name of the group you want to reference in the directory.
Example: Press the **4/DIM** key repeatedly to toggle among the seven available characters associated with that key: 4 → G → H → I → g → h → i → 4...
6. Press the **ENT** key to save the first letter in the name and move to the next letter to the right.
7. Repeat steps 5 and 6 to complete the name. The name can have a maximum of 11 characters. Press the **ENT** key to move to the next space. This method can also be used to enter a blank space in the name. If you enter a wrong character, press the [BACK] soft key until the wrong character is selected, then enter the correct character.
8. After the name has been entered, press and hold the **ENT** key to advance to the Group call MMSI number entry (ID line).
9. Enter the MMSI number (nine digits: first digit permanently set to "0"). If you enter a wrong digit, press the [BACK] soft key until the wrong digit is selected, then press the correct numeric key.
10. Press and hold the **ENT** key to save the data.
11. Press the [QUIT] soft key several times to return to radio operation.

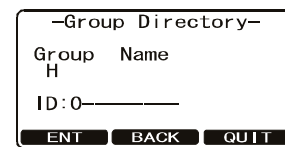
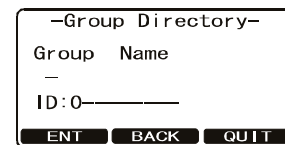
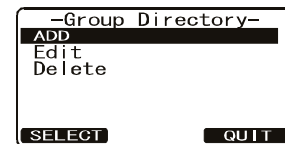

3.7.2 How to transmit a group call

Transmit group call to group registered in the group Directory

1. Press the **CALL/M N** key to show the DSC Menu.
2. Rotate the **CH** knob to select group then press the **SELECT** soft key to show the group Directory menu.
3. Rotate the **CH** knob to select the group call name you want to contact then press the **SELECT** soft key.
4. Rotate the **CH** knob to select the operating channel you want to communicate on then press the **SELECT** soft key.
5. Press the **ES** soft key to transmit the group call signal.
6. The display shows Transmitting while the group call signal is being sent.
7. After the group call is transmitted, all the radios in the group call automatically switch to the designated channel.
 Listen to the channel to make sure it is not busy, then press the microphone's **PTT** switch and call the other vessel you desire to communicate with.

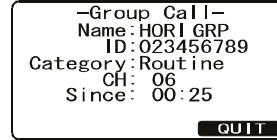
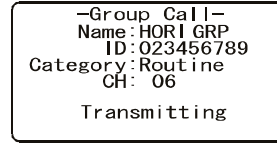
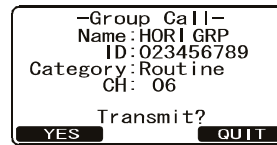
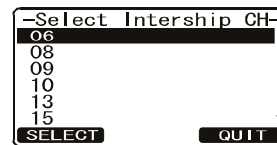

Transmit group call to group not registered in the group Directory

This feature allows you to contact a group of vessels by entering their group call MMSI manually.

1. Press the **CALL/M N** key to show the DSC Menu.
2. Rotate the **CH** knob to select group then press the **SELECT** soft key to show the group Directory menu.
3. Press the **New ID** soft key.
4. Select **Manual** with the **CH** knob then press the **SELECT** soft key.
5. Enter the MMSI number (nine digits: first digit permanently set to 0). If you enter a wrong digit, press the **AC** soft key until the wrong digit is selected, then press the correct numeric key.
6. Press and hold the **SELECT** soft key.

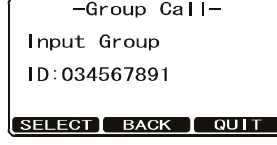
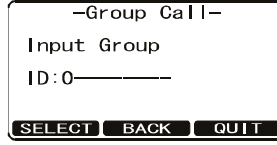
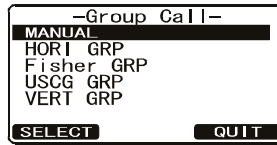

7. Rotate the **CH** knob to select the operating channel you want to communicate on then press the **SELECT** soft key.

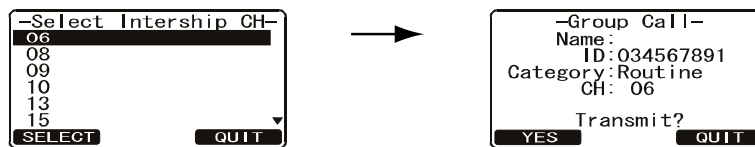

8. Press the **PTT** soft key to transmit the group call signal.
9. The display shows **Transmitting** while the group call signal is being sent.
10. After the group call is transmitted, all the radios in the group automatically switch to the designated channel.
11. Listen to the channel to make sure it is not busy, then press the **PTT** button and talk into the microphone to the group call of vessels.

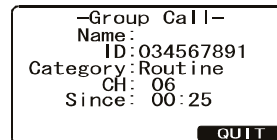
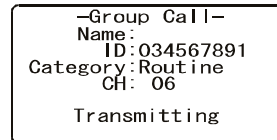

3.7.3 How to receive a group call

1. When a group call is received, the FM-4721 releases the ringer alarm and the radio automatically switches to the requested channel.
2. Press any key to stop the alarm.
3. Follow the procedure in step 3 in section 3.4.2.
4. Monitor the channel for the person calling the group for a message.
5. If you want to respond, monitor the channel to make sure it is clear, then press the microphone's **PTT** switch and talk into the microphone to the group of vessels.
6. Press any key to return to radio operation.

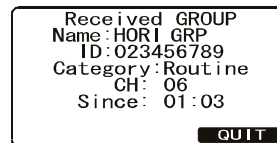
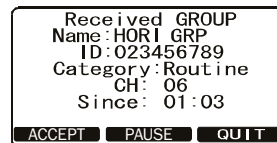

Note: After a group call is received, the time the call was made and the ship's MMSI or vessels name that made the call appear on the display.

3.8 Position Request Call

Advancements in DSC have made it possible to poll the location of another vessel and show the position of that vessel on the display of the FM-4721. FURUNO has taken this feature one step further. If a compatible GPS chart plotter is connected to the FM-4721, the polled position of the vessel is shown on the display of the GPS chart plotter making it easy to navigate to the location of the polled vessel.

Note: The other vessel must have an operating GPS receiver connected to its DSC radio and must not have its radio set to deny position requests. (Refer to section 3.5 to enter information into the individual directory).

3.8.1 How to set up a position request reply

The FM-4721 automatically (default setting) or manually transmits your position when requested by another vessel. This selection is important if you are concerned about someone polling the position of your vessel that you may not want to. In the manual mode the MMSI or the name of the person making the request appears on the display, allowing you to choose to transmit your position to the requesting vessel or not.

1. Press and hold down the **CALL/MENU** key until the [Setup Menu] appears.
2. Rotate the **CH** knob to select [DSC Setup] menu then press the [SELECT] soft key.
3. Select [Position Reply] with the **CH** knob then press the [SELECT] soft key.
4. Select [Automatic] or [Manual] then press the [ENT] soft key to save setting. [Automatic]: The radio automatically transmits your vessel's position to the requesting vessel. [Manual]: The display of the FM-4721 shows who is requesting the position. Press the [YES] soft key to transmit your position to the requesting vessel.
5. Press the [QUIT] soft key several times to return to radio operation.

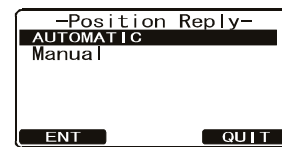

3.8.2 How to set up the position request ringer

The position request ringer, which beeps when a position request is received, can be turned off.

1. Press and hold down the **CALL/MENU** key until the [Setup Menu] appears.
2. Rotate the **CH** knob to select [DSC Setup] menu then press the [SELECT] soft key.
3. Select [DSC Beep] with the **CH** knob then press the [SELECT] soft key.
4. Select [POS Request] with the **CH** knob then press the [ENT] soft key.
5. Select [Off] with the **CH** knob then press the [ENT] soft key to save the setting.
6. Press the [QUIT] soft key several times to return to radio operation.

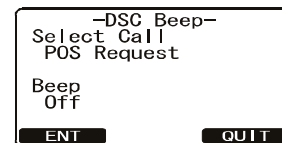
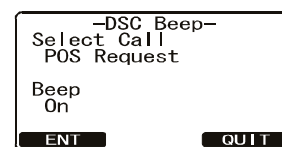

To re-enable the ringer tone, Select [On] in step 5 of the procedure.

Note: When the [Position Reply] is set to [Automatic], the position request ringer does not sound regardless of the setting in this procedure.

3.8.3 How to transmit a Position Request call to another vessel

Request position of vessel registered in the Individual Directory

1. Press the **CALL/MENU** key to show the [DSC Menu].
2. Rotate the **CH** knob to select [POS Request] then press the [SELECT] soft key.
3. Rotate the **CH** knob to select a name then press the [SELECT] soft key. The Category screen appears.
4. Rotate the **CH** knob to select [.Routine] or [Safety] then press the [SELECT] soft key.
5. Press the [YES] soft key to transmit the position request DSC call. When the FM-4721 receives the position from the polled vessel it appears on the display and is also transferred and shown on a GPS chart plotter (if connected to the FM-4721).
6. Press the [QUIT] soft key to return to radio operation.

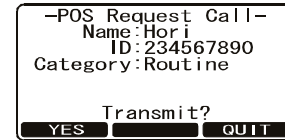
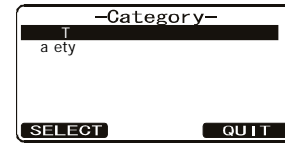
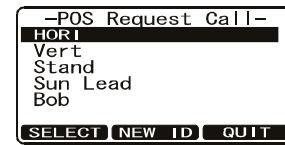

Request position of vessel not registered in the Individual Directory

1. Press the **CALL/MENU** key to show the [DSC Menu].
2. Rotate the **CH** knob to select [POS Request] then press the [SELECT] soft key to show the [POS Request Call] display.
3. Press the [NEW ID] soft key to show the following display.
4. Select [Manual] with the **CH** knob then press the [SELECT] soft key.
5. Enter the MMSI number (nine digits) which you want to contact. If you enter a wrong digit, press the [BACK] soft key until the wrong digit is selected, then press the correct numeric key.
6. After you have entered the MMSI number, press and hold the [SELECT] soft key. The Category screen appears.
7. Rotate the **CH** knob to select [Routine] or [Safety] then press the [SELECT] soft key.
8. Press the [YES] soft key to transmit the position request DSC call.
9. The position of the polled vessel appears on the display and is also transferred to the GPS chart plotter (if connected to the FM-4721).
10. Press the [QUIT] soft key to return to radio operation.

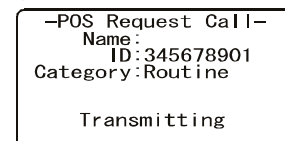
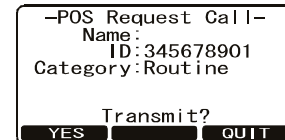
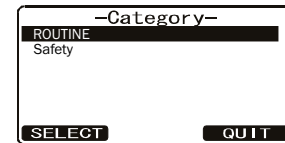
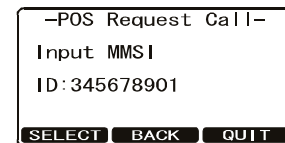
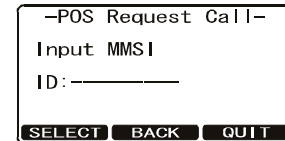
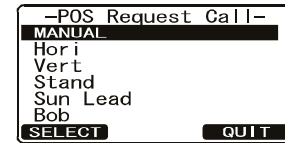
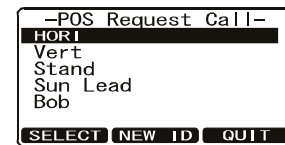

3.8.4 When you receive a Position Request call

When you receive a Position Request call from another vessel, a ringing alarm sounds and "POS Request" appears on the display. The FM-4721 automatically or manually replies to the request depending on the setting of [Position Reply] in the [DSC Setup] menu.

Automatic transmission of your position

1. When you receive a Position Request call, position coordinates are automatically transmitted to the vessel that requested your vessel's position.
2. 10 seconds after your position is transmitted, the radio automatically changes to the requested channel. Press the [QUIT] soft key to exit from the position request display.

Manual transmission of your position

1. When a Position Request call is received from another vessel, the display looks something like the one shown below.
2. A ringing alarm sounds four times. To transmit your vessel's position to the requesting vessel, press the [REPLY] soft key. Or to exit from the position request display without transmitting position, press the [QUIT] soft key.

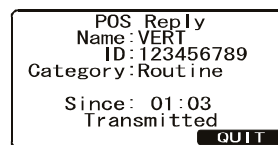
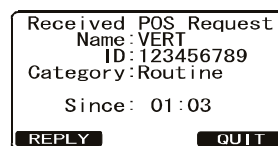

3.9 Position Report Call

A Position Report call transmits your position to another vessel. Your vessel must have an operating GPS receiver connected to the FM-4721 to transmit your position. The MMSI of the vessel can be one you have programmed, or entered manually.

3.9.1 How to enable, disable the position report ringer

A ringer sounds when you receive a request for your position. Enable or disable the position report ringer as follows:

1. Press and hold down the **CALL/MENU** key until the [Setup Menu] appears.
2. Rotate the **CH** knob to select [DSC Setup] menu then press the [SELECT] soft key.
3. Select [DSC Beep] with the **CH** knob then press the [SELECT] soft key.
4. Rotate the **CH** knob to select [POS Report] then push the [ENT] soft key.
5. Rotate the **CH** knob to select [Off] then push the [ENT] soft key.
6. Press the [ENT] soft key to save the selected setting.
7. Press the [QUIT] soft key several times to return to radio operation.

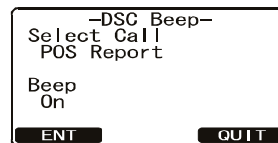

To re-enable the ringer tone, select [On] at step 4 in the procedure.

3.9.2 How to transmit a Position Report call

Transmit your position to vessel registered in the Individual Directory

1. Press the **CALL/MENU** key to show the [DSC Menu].
2. Rotate the **CH** knob to select [POS Report] then press the [SELECT] soft key.
3. Rotate the **CH** knob to select a name in the directory then press the [SELECT] soft key. The Category screen appears. Rotate the **CH** knob to select a category then press the [SELECT] soft key.
4. Press the [YES] soft key to transmit your position to the selected vessel.
5. Press the [QUIT] soft key to return to radio operation.

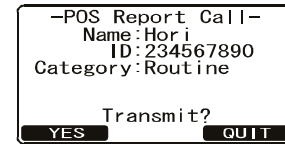
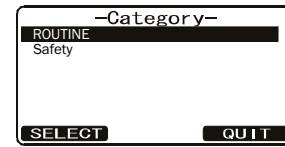

Transmit your position to vessel not registered in the Individual Directory

1. Press the **CALL/MENU** key to show the [DSC Menu].
2. Rotate the **CH** knob to select [POS Report] then press the [SELECT] soft key.
3. Press the [New ID] soft key.
4. Select [Manual] with the **CH** knob then press the [SELECT] soft key.
5. Enter the MMSI number that you want to contact. If you enter a wrong digit press the [BACK] soft key until the wrong number is selected, then press the correct numeric key.
6. Press and hold the [SELECT] soft key. The Category screen appears. Rotate the **CH** knob to select a category then press the [SELECT] soft key.
7. Press the [YES] soft key to transmit your position to the selected vessel.
8. Press the [QUIT] key to return to radio operation.

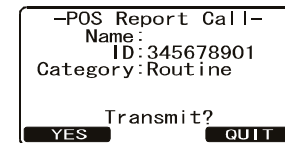
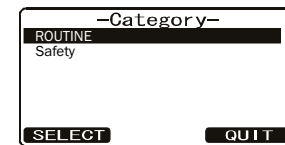
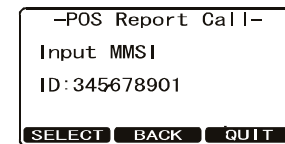
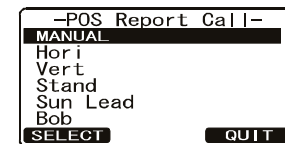
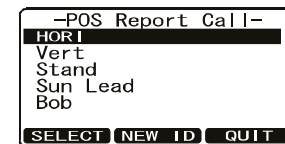

3.9.3 When you receive a Position Report call

When another vessel transmits its position to the FM-4721 the following occurs:

1. The ringer sounds and NMEA sentences DSC, DSE are outputted to a GPS chart plotter (if connected to the FM-4721).
2. Press the **CLR/** key to stop the ringer.
3. Rotate the **CH** knob to see the position information of the vessel then press the **SELECT** soft key.
4. Press the **EXIT** soft key to close the display and return to radio operation.

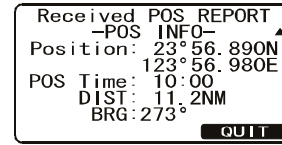
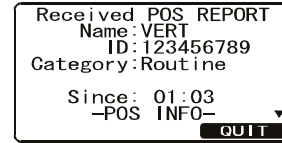

3.1 A to DSC Polling

The FM-4721 has the capability to automatically track four stations programmed into the individual directory.

The following procedure allows the time interval between position requests to be set-up.

1. Press and hold down the **CALL/M N** key until the Setup Menu appears.
2. Rotate the **CH** knob to select DSC Setup menu then press the **SE ECT** soft key.
3. Select Auto POS Interval with the **CH** knob then press the **SE ECT** soft key.
4. Rotate the **CH** knob to select the desired interval time (1, 2, 3, 4, 5, 10, 20, 30, and 40 minutes) and press the **ENT** soft key.
5. Press the **IT** soft key numerous times to exit to the radio mode.

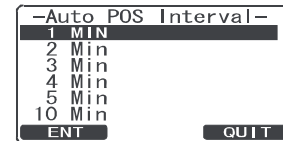

3.1 .1 Selecting stations to be automatically polled tracked

Note: The radio uses the individual directory to select stations. Refer to paragraph 3.5.1 and enter MMSI of stations you want to poll before proceeding.

1. Press the **CALL/M N** key to show the DSC Menu .
2. Rotate the **CH** knob to select Auto POS Polling , then press the **SE ECT** soft key.
3. Rotate the **CH** knob to select the Select Address then press the **SE ECT** soft key. The radio shows four calling stations to be selected, select Call 1 and press the **SE ECT** soft key.
4. The radio shows the stations programmed in the Individual directory. Rotate the **CH** knob to select the desired station and press the **SE ECT** soft key.
5. Repeat steps 3 and 4 for Call 2 , Call 3 and Call 4 entries.
6. When finished, press the **IT** soft key numerous times to exit to the radio mode.

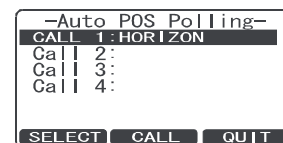
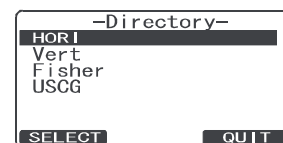
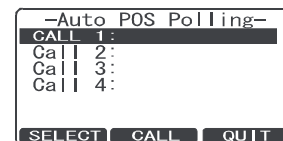
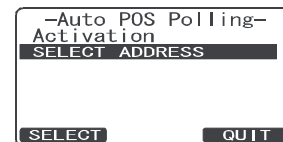

3.10.2 Enable/Disable auto DSC polling

1. Press the **CALL/MENU** key to show the [DSC Menu].
2. Rotate the **CH** knob to select [Auto POS Polling] then press the [SELECT] soft key.
3. Rotate the **CH** knob to select [Activation] then press the [SELECT] soft key.
4. Select [Start] to enable transmissions to the stations or [Stop] to disable transmissions to the stations.
5. Press the [ENT] soft key.
6. Press the [QUIT] soft key several times to exit to the radio mode.

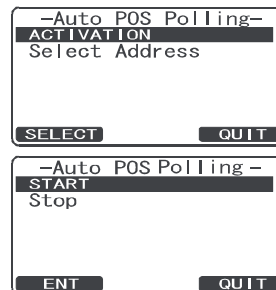

Note 1: “(A)” appears on the screen when Auto DSC polling is active.

Note 2: When the radio receives position reports from a called vessel, the NMEA 0183 DSC and DSE sentences are output to a GPS chart plotter.

3.11 Auto CH Switch Time

This feature allows you to change the switching time which is automatically shifted to the requested channel when the Distress Alert, All Ships Call, and Group Call are received.

1. Press and hold down the **CALL/MENU** key until the [Setup Menu] appears.
2. Rotate the **CH** knob to select [DSC Setup] menu.
3. Press the [SELECT] soft key, then select [Auto CH Switch Time] with the **CH** knob.
4. Press the [SELECT] soft key, then rotate the **CH** knob to the desired time.
5. Press the [ENT] soft key to store the selected setting.
6. Press the [QUIT] soft key several times to return to radio operation.

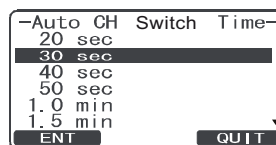
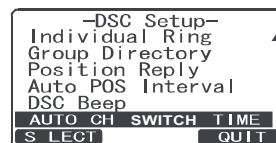

3.12 DSC Test

This function contacts another DSC-equipped vessel to test your DSC radio for proper operation. To use this feature, the radio that you transmit the test call to must have the DSC test feature.

To do the DSC test, enter the MMSI of another vessel. The MMSI can be one you have programmed into the individual directory or a manually entered one.

3.12.1 How to make a DSC test call with MMSI in the Individual Directory

1. Press the **CALL/MENU** key to show the [DSC Menu].
2. Rotate the **CH** knob to select [DSC Test] then press the [SELECT]soft key.
3. Rotate the **CH** knob to select a vessel (station) then press the [SELECT] soft key.
4. Press the [YES] soft key to transmit the DSC test call to the other vessel.

After the radio receives a test call reply from the vessel, the radio rings and shows the "TEST ACK" display, which confirms the radio you called received the test call.

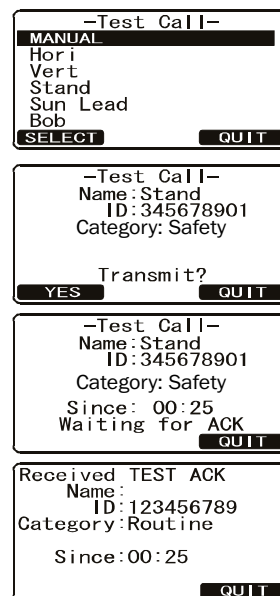

3.12.2 How to make a DSC test call by manually entering MMSI

1. Press the **CALL/MENU** key to show the [DSC Menu].
2. Rotate the **CH** knob to select [DSC Test] then press the [SELECT] soft key.
3. Rotate the **CH** knob to select [Manual] then press the [SELECT] soft key.
4. Enter the MMSI number which you want to contact.
5. Press and hold the [SELECT] soft key to show the [Test Call] page.
6. Press the [YES] soft key to transmit the DSC test call to the other vessel.

After the radio receives a test call reply from the vessel, the radio rings and shows the "TEST ACK" display, which confirms the radio you called received the test call.

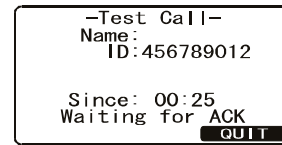
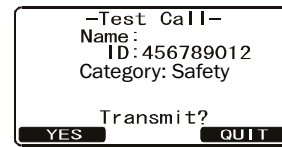
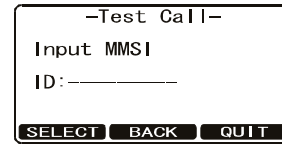

4. GENERAL SETUP

The procedures in this chapter can also be done from the HS-4721 Handset.

4.1 Display Contrast

The display contrast can be adjusted to suit environmental conditions.

1. Press and hold down the **CALL/MENU** key until the [Setup Menu] appears.
2. Rotate the **CH** knob to select [General Setup] menu then press the [SELECT] soft key.
3. Rotate the **CH** knob to select [Contrast] then press the [SELECT] soft key.
4. Rotate the **CH** knob to set the contrast then press the [ENT] soft key to store the selected level. The contrast level can be set from 0 to 31.
5. Press the [QUIT] soft key several times to return to radio operation.

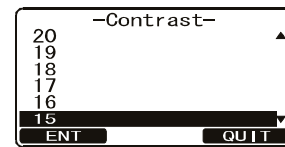

4.2 Time Offset

If you want to use local time, set the time difference between UTC and local time. The offset is added or subtracted from the time received from the GPS receiver or chart plotter. Time is only displayed when a GPS receiver or Chart Plotter is connected.

1. Press and hold down the **CALL/MENU** key until the [Setup Menu] appears.
2. Select [General Setup] with the **CH** knob then press the [SELECT] soft key.
3. Select [Time Offset] with the **CH** knob then press the [SELECT] soft key.
4. Rotate the **CH** knob to select time offset of your location then press the [ENT] soft key to store the time offset. Set "00:00" to use UTC (Universal Time Coordinated or GPS Satellite Time).
5. Press the [QUIT] soft key several times to return to radio operation.

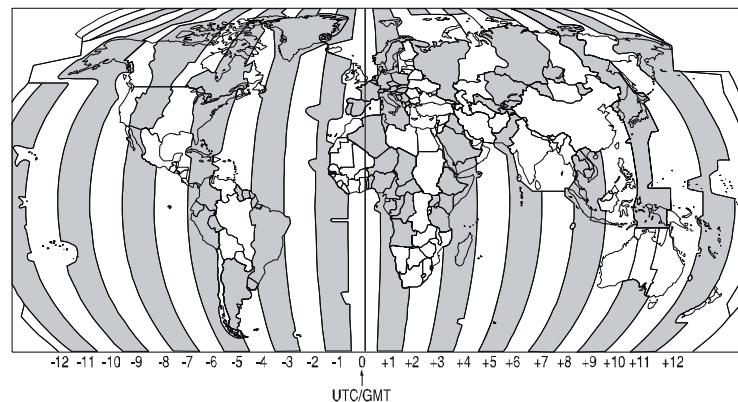

4.3 Time Area

Time can be shown in UTC time or local time with the offset.

1. Press and hold down the **CALL/MENU** key until the [Setup Menu] appears.
2. Select [General Setup] with the **CH** knob then press the [SELECT] soft key.
3. Rotate the **CH** knob to select [Time Area] then press the [SELECT] soft key.
4. Rotate the **CH** knob to select [UTC] or [Local] then press the [ENT] soft key to store the selected setting.
5. Press the [QUIT] soft key several times to return to radio operation.

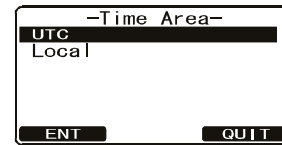

4.4 Time Notation

You can show time in 12-hour or 24-hour format.

1. Press and hold down the **CALL/MENU** key until the [Setup Menu] appears.
2. Select [General Setup] with the **CH** knob then press the [SELECT] soft key.
3. Rotate the **CH** knob to select [Time Display] then press the [SELECT] soft key.
4. Rotate the **CH** knob to select [12 Hour] or [24 Hour] then press the [ENT] soft key to store the selected setting.
5. Press the [QUIT] soft key several times to return to radio operation.



4.5 Units of Measurement

Select the unit of measurement for speed and distance.

Note: A GPS receiver must be connected to the radio to show speed and distance.

1. Press and hold down the **CALL/MENU** key until the [Setup Menu] appears.
2. Select [General Setup] with the **CH** knob then press the [SELECT] soft key.
3. Rotate the **CH** knob to select [Unit of Measure] then press the [SELECT] soft key.
4. Rotate the **CH** knob to select [Speed] or [Distance] then press the [SELECT] soft key.

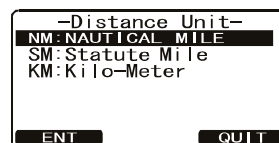
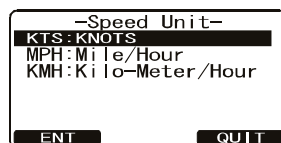

5. Rotate the **CH** knob to select a unit. Available selections are [KTS (Knots)], [MPH (Mile/Hour)] or [KMH (Kilo-Meter/Hour)] for speed, and [NH (Nautical Mile)], [SM (Statute Mile)] or [KM (Kilo-Meter)] for distance.
6. Press the [ENT] soft key to store the selected setting.
7. Press the [QUIT] soft key several times to return to radio operation.

4.6 COG Display Format

GPS COG (Course Over Ground) can be shown in True or Magnetic.

Note: A GPS must be connected to the radio to be able to show COG.

1. Press and hold down the **CALL/MENU** key until the [Setup Menu] appears.
2. Select [General Setup] with the **CH** knob then press the [SELECT] soft key.
3. Rotate the **CH** knob to select [Magnetic] then press the [SELECT] soft key.
4. Rotate the **CH** knob to select [True] or [Magnetic] then press the [ENT] soft key to store the selected setting.
5. Press the [QUIT] soft key several times to return to radio operation.

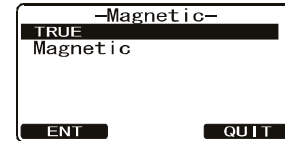

4.7 Manual Input of the Position (Lat/Lon)

You may transmit the Latitude/Longitude of your vessel manually if you don't have a GPS receiver or something is wrong with your GPS receiver. When there is no position input, the GPS icon appears (flashing), as shown in the figure at the bottom of this page.

1. Press and hold down the **CALL/MENU** key until the [Setup Menu] appears.
2. Select [General Setup] with the **CH** knob then press the [SELECT] soft key.
3. Rotate the **CH** knob to select [Position Input] then press the [SELECT] soft key.
4. Enter the latitude/longitude of your vessel and UTC time in 24-hour notation.
To set coordinate: North (N): **6/DW** key South (S): **7/SQRM** key East (E): **3/SCAN** key West (W): **9/FOG** key
You may backspace the cursor by pressing the [BACK] soft key, if you made a mistake.
5. When you have completed the input of position and time, press and hold down the [ENT] soft key for two seconds to save the setting.
6. Press the [QUIT] soft key several times to return to radio operation.

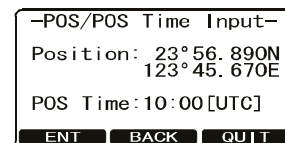
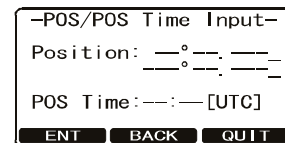

The indication "POS Data Manual" appears when position is input manually.

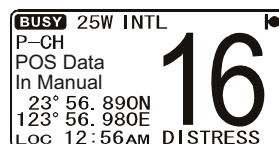

← GPS icon (flashing)
(Indicates no position data
from GPS receiver.)

4.8 Key Beep

Set the level of the key beep that is emitted when a key is pressed.

1. Press and hold down the **CALL/MENU** key until the [Setup Menu] appears.
2. Select [General Setup] with the **CH** knob then press the [SELECT] soft key.
3. Rotate the **CH** knob to select [Key Beep] then press the [SELECT] soft key.
4. Rotate the **CH** knob to select the desired level then press the [ENT] soft key to store the selected level. The beep level can be set from [Level 1] to [Level 6], [High], or [Off].
5. Press the [QUIT] soft several times to return to radio operation.

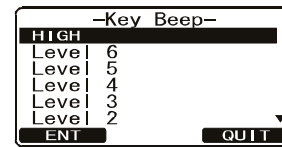

4.9 Treble and Bass Audio Tone Control

The treble and bass of the speaker can be adjusted for best listening in noisy environments. The effect is similar to the treble and bass controls on stereo equipment.

1. Press and hold down the **CALL/MENU** key until the [Setup Menu] appears.
2. Select [General Setup] with the **CH** knob then press the [SELECT] soft key.
3. Rotate the **CH** knob to select [Tone Control] then press the [SELECT] soft key.
4. Select [Bass] with the **CH** knob then press the [ENT] soft key.
5. Rotate the **CH** knob to select desired audio response in the lower frequency range then press the [ENT] soft key to store the selected setting. The setting range is -6 to +6.
6. Select [Treble] with the **CH** knob then press the [ENT] soft key.
7. Rotate the **CH** knob to select desired audio response in the higher frequency range then press the [ENT] soft key to store the selected setting. The setting range is -6 to +6.
8. Press the [QUIT] soft key several times to return to radio operation.



4.10 Fog Alert Tone Frequency

Set the fog alert tone according to the size your vessel, as shown below.

70 to 200 Hz: Vessel that are 200 meters or more in length

130 to 350Hz: Vessel that are 75 meters but less than 200 meters in length

250 to 525 Hz: Vessel that are 20 meters but less than 75 meters in length

250 to 525 Hz: Vessel that are 12 meters but less than 20 meters in length

Note: The default radio fog frequency is set to 400Hz. In most cases this frequency should not be changed unless the vessel is very large.

1. Press and hold down the **CALL/MENU** key until the [Setup Menu] appears.
2. Select [General Setup] with the **CH** knob then press the [SELECT] soft key.

3. Rotate the **CH** knob to select [Fog Frequency] then press the [SELECT] soft key
4. Rotate the **CH** knob to select the desired tone frequency then press the [ENT] soft key to store the selected setting.
5. Press the [QUIT] soft key several times to return to radio operation.

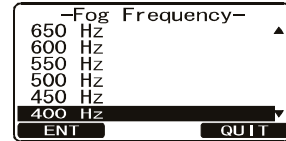

4.11 How to Name the Radio or Handset

You can change the name of the radio or second station microphone. Example: "Radio" to "Cabin", "RAM1" to "Flybridge".

1. Press and hold down the **CALL/MENU** key until the [Setup Menu] appears.
2. Select [General Setup] with the **CH** knob then press the [SELECT] soft key.
3. Rotate the **CH** knob to select [Station Name] then press the [SELECT] soft key.
4. With the second station microphone connected, rotate the **CH** knob to select the unit ([Radio], [RAM1] or [RAM2]) to be named then press the [ENT] soft key.
5. Press applicable key to enter the first letter of the new station name.
Example: Press the **2/MEM** key repeatedly to toggle among the seven available characters associated with that key: 2 → A → B → C → a → b → c → 2...
6. Press the **ENT** key to store the first letter in the name and move to the next letter to the right.
7. Repeat steps 5 and 6 to complete the name. The name can have a maximum of 8 characters. If you do not use all 8 characters, press the **ENT** key to move to the next space. This method can also be used to enter a blank space in the name. If you enter a wrong character, press the [BACK] soft key until the wrong character is selected, then enter the correct character.
8. Press and hold the [ENT] soft key to enter the name.
9. If you want to enter the name of the connected HS-4721 Handset, repeat steps 4 through 8.
10. Press the [QUIT] soft key several times to return to radio operation.

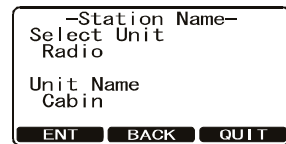
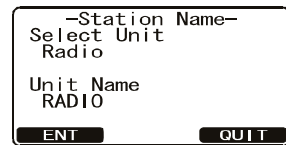

4.12 Soft Keys

This section shows you how to set up the soft keys. You can select the number of soft keys to use, program the soft keys and select how long to show the soft key icon after a soft key is pressed.

4.12.1 Transceiver unit

1. Press and hold down the **CALL/MENU** key until the [Setup Menu] appears.
2. Select [General Setup] with the **CH** knob then press the [SELECT] soft key.
3. Rotate the **CH** knob to select [Soft Keys] then press the [SELECT] soft key.
4. Rotate the **CH** knob to select [Number of Soft Keys] then press the [SELECT] soft key.
5. Rotate the **CH** knob to select the number of soft keys (3 through 10) to use then press the [ENT] soft key.
6. Rotate the **CH** knob to select [Key Assignment] then press the [SELECT] soft key (to assign the use of selected soft keys).

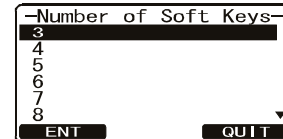

→
Select Key Assignment;
press [SELECT] soft key.

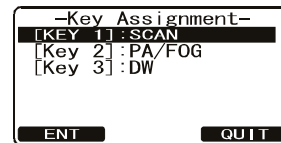

7. Rotate the **CH** knob to select the key ([Key 1], [Key 2], [Key 3], etc.) then press the [SELECT] soft key.
8. Rotate the **CH** knob to select a new function then press the [ENT] soft key. See the table below for functions.
9. Press the [QUIT] soft key.
10. Rotate the **CH** knob to select [Key Timer] then press the [SELECT] soft key. [Key Timer] sets how long to display a soft key icon after a soft key is pressed.

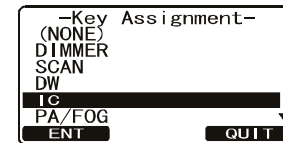

→
Select Key Timer;
press [SELECT] soft key.

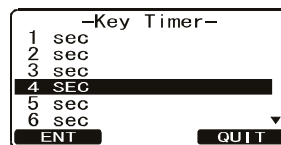

11. Rotate the **CH** knob to select the time then press the [ENT] soft key to store the selected setting.
12. Press the [QUIT] soft key several times to return to radio operation.

Function	Description
[DIMMER]	Selects the menu for the display and key back light intensity.
[SCAN]	Starts and stops scanning.
[DW]	Starts and stops dual watch scan.
[IC]	Activates Intercom between radio and HS-4721 Handset.
[PA/FOG]	Activates the PA / foghorn function.
[PRESET]	Programs or deletes the preset memory channel.
[SCRAMBLER]	Activates the voice scrambler.

4.12.2 Handset HS-4721

1. Press and hold down the **CALL/M N** key until the Setup Menu appears. Select ENERA SET P with the ▲ or ▼ key then press the SE ECT soft key.
2. Press the ▼ key to select Soft eys then press the ENT soft key.
3. Press the ▼ key to select Number of Soft eys then press the SE ECT soft key.
4. Press the ▲ or ▼ key to select the number of soft keys (3 through 10) to use then press the ENT soft key.
5. Press the ▲ or ▼ key to select eey Assignment (to assign the use of selected soft keys) then press the SE ECT soft key.
6. Press the ▲ or ▼ key to select the key (E 1 , E 2 , E 3 , etc.) then press the SE ECT soft key. Press the ▲ or ▼ key to select a new function to be assigned then press the ENT soft key. Available functions are listed on the previous page. Repeat step 6 to program the other soft keys.
7. Press the ▲ or ▼ key to select eey Timer then press the SE ECT soft key. eey Timer sets how long a soft key icon is shown on the display after a soft key is pressed.
 - Press the ▲ or ▼ key to select the time then press the ENT soft key to store the selected setting.
9. Press the IT soft key several times to return to handset operation.

4.13 Calendar Set p

The FM-4721 has a built in clock to remember date, time, latitude and longitude. A PS receiver not only provides position data but also updates the calendar. Refer to section 4.5 Accessory Cable.

PS recei er connected: The FM-4721 automatically updates the calendar date and time information after being connected for one hour.

PS recei er not connected: The date and time must be manually entered into the Calendar Menu in order for the clock to operate. The time you enter is your local time in TC format.

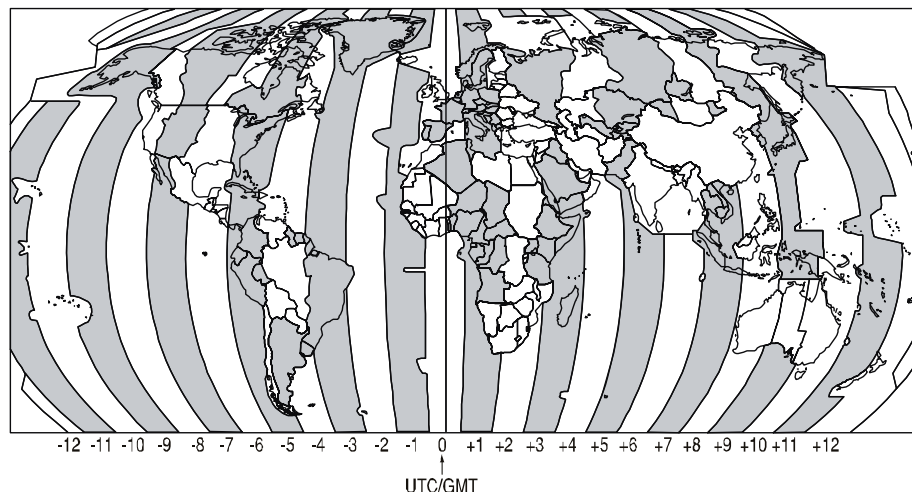

4. ENERA SET P

Example 1: If you are East of TC time, add the offset to your time.

City	Rome
Offset	1
Time (convert local time to 24 hour)	4:00PM (12hour) or 16:00 (24hour)
Calculate 24hour local - Offset (East of TC)	16:00 - 01:00 15:00

Example 2: If you are west of TC time, subtract the offset from your time.

City	New or
Offset	-5
Time (convert local time to 24 hour)	4:00PM (12hour) or 16:00 (24hour)
Calculate 24hour local - Offset (est of TC)	16:00 05:00 21:00

1. Press and hold down the **CALL/M N** key until the Setup Menu appears.

2. Select General Setup with the **CH** knob then press the **SELECT** soft key.

3. Rotate the **CH** knob to select Calendar then press the **SELECT** soft key. Repeat this step.

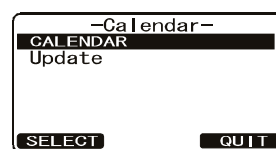

4. Enter the current date (yyyy/mm/dd) with the numeric keys. If you made a mistake, press the **AC** soft key until the wrong number is selected, then enter the correct number.

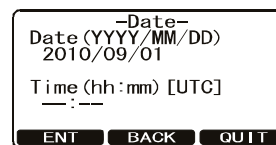

5. Use the map on the previous page to find the TC time of your position.

Note: For daylight savings time subtract one hour to the offset in your time zone.

6. To enter the time, press the **ENT** soft key until the first digit in the Time line is selected then enter the time with the numeric keys.

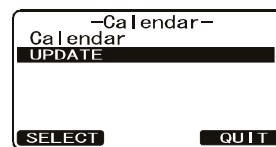

7. Press and hold the **ENT** soft key to store the selected setting.

8. Select Update with the **CH** knob then press the **SELECT** soft key.

9. Turn the **CH** knob to select the method of the time adjustment, Automatic or Manual then press the **ENT** soft key to store the selected setting.

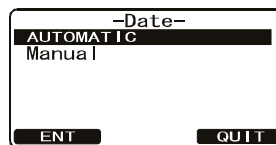

10. Press the **QUIT** soft key several times to return to radio operation.

Note: The calendar is backed up for approximately one week after the power is turned off.

4.14 How to Set the Timeouts

A timeout determines the number of minutes the radio should keep a given screen displayed before it restores the standby display, if no radio operation is detected. There are three types of screens for which you can set a timeout: menu, DSC non-distress, and DSC distress. Set the timeout for these screens as follows:

1. Long-press the **CALL/MENU** key to show the [Setup Menu].
2. Use the **CH** knob to select [DSC Setup] then press the [SELECT] soft key.
3. Use the **CH** knob to select [No Act Timer on Menu], [No Act Timer on DSC] or [No Act Timer on DIST] as appropriate then press the [SELECT] soft key. For example, select [No Act Timer on Menu]. (The choices for each menu are the same.)



No Act Timer on Menu: Set the number of minutes to keep a menu screen displayed before the standby screen is restored, if there is no radio operation. **No Act Timer on DSC:** Set the number of minutes to wait before the standby screen is restored, if there is no radio operation after a DSC non-distress message is received. **No Act Timer on DIST:** Set the number of minutes to wait before the standby screen is restored, if there is no radio operation after a DSC distress message is received.

4. Use the **CH** knob to select the number of minutes desired (1, 2, 3, 4, 5, 10, 15, 20) or [OFF] then press the [ENT] soft key. [OFF] keeps a screen displayed until radio operation is detected.
5. Press the [QUIT] soft key several times to close the menu and return to radio operation.

4. GENERAL SETUP

This page is intentionally left blank.

5. CHANNEL FUNCTION SETUP

5.1 CH Group

Select the channel group among USA, Canada, and International.

1. Press and hold down the **CALL/MENU** key until the [Setup Menu] appears.
2. Rotate the **CH** knob to select [CH FUNCTION Setup] then press the [SELECT] soft key.
3. Rotate the **CH** knob to select [CH Group] then press the [SELECT] soft key.
4. Rotate the **CH** knob to select desired channel group among [USA], [INTL] and [CAN] (Canada) then press the [ENT] soft key to store the selected setting.
5. Press the [QUIT] soft key several times to return to radio operation.

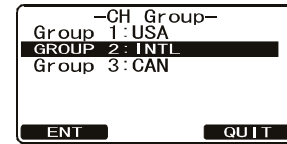

5.2 Scan Memory

In order to scan channels, store the desired scan channels in the scan memory as shown below.

1. Press and hold down the **CALL/MENU** key until the [Setup Menu] appears.
2. Rotate the **CH** knob to select [CH Function Setup] then press the [SELECT] soft key.
3. Rotate the **CH** knob to select [Scan Memory CH] then press the [SELECT] soft key.
4. Rotate the **CH** knob to select the channel to scan then press the [ADD] soft key. "MEM" appears on the display to indicate that the channel has been memorized to the scan channel.
5. Repeat step 4 for to select another channel.
6. To delete a channel from the list, select the channel then press the [DELETE] soft key. "MEM" icon disappears from the display.
7. When you have completed your selection, press the [QUIT] soft key several times to return to radio operation.

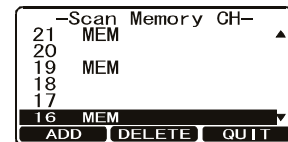

5.3 Scan Type

Select the scan mode between [Memory Scan] and [Priority Scan].

1. Press and hold down the **CALL/MENU** key until the [Setup Menu] appears.
2. Rotate the **CH** knob to select [CH Function Setup] then press the [SELECT] soft key.
3. Select [Scan Type] with the **CH** knob then press the [SELECT] soft key.
4. Rotate the **CH** knob to select [Priority Scan] or [Memory Scan] then press the [ENT] soft key to store the selected setting.
5. Press the [QUIT] soft key several times to return to radio operation.

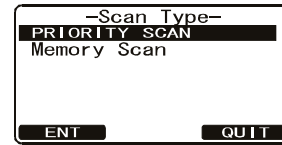

5.4 Scan Resume

Set the time the FM-4721 waits after a transmission ends until the radio resumes channel scanning.

1. Press and hold down the **CALL/MENU** key until the [Setup Menu] appears.
2. Rotate the **CH** knob to select [CH Function Setup] then press the [SELECT] soft key.
3. Select [Scan Resume] with the **CH** knob then press the [SELECT] soft key.
4. Rotate the **CH** knob to select the desired resume time then press the [ENT] soft key to store the selected setting. [OFF] resumes scanning after the other station stops transmitting (carrier drops).
5. Press the [QUIT] soft key several times to return to radio operation.

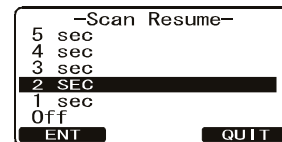

5.5 Priority CH

The default priority channel in channel scan is CH16. To select a different channel, do the following:

1. Press and hold down the **CALL/MENU** key until the [Setup Menu] appears.
2. Rotate the **CH** knob to select [CH Function Setup] then press the [SELECT] soft key.
3. Select [Priority CH] with the **CH** knob then press the [SELECT] soft key.
4. Rotate the **CH** knob to select the desired channel to be a priority CH then press the [ENT] soft key.
5. Press the [QUIT] soft key several times to return to radio operation.

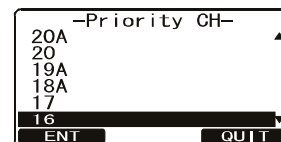

5.6 Weather Alert Setup

In the event of extreme weather disturbances, such as storms and hurricanes, the NOAA (National Oceanic and Atmospheric Administration) sends a weather alert accompanied by a 1050 Hz tone and subsequent weather report on one of the NOAA weather channels. You can turn this alert on or off.

1. Press and hold down the **CALL/MENU** key until the [Setup Menu] appears.
2. Rotate the **CH** knob to select [CH Function Setup] then press the [SELECT] soft key.
3. Select [WX Alert] with the **CH** knob then press the [SELECT] soft key.
4. Rotate the **CH** knob to select [On] or [Off] then press the [ENT] soft key to store the selected setting.
5. Press the [QUIT] soft key several times to return to radio operation.

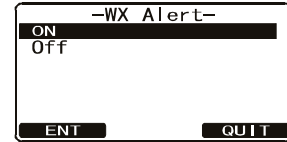

5.7 Channel Naming

When the radio mode is in use, the display shows a name under the channel number selected. This is name of the current channel. You can customize channel names as follows:

1. Press and hold down the **CALL/MENU** key until the [Setup Menu] appears.
2. Rotate the **CH** knob to select [CH Function Setup] then press the [SELECT] soft key.
3. Select [CH Name] with the **CH** knob then press the [SELECT] soft key.
4. Rotate the **CH** knob to select a channel then press the [ENT] soft key.
5. Press applicable key to enter the first letter of the new channel name.
Example: Press the **4/DIM** key repeatedly to toggle among the seven available characters associated with the key: 4 → G → H → I → g → h → i → 4...
6. Press the [ENT] soft key to store the first letter in the name and move to the next letter to the right.
7. Repeat steps 5 and 6 to complete the name. The name can have a maximum of 16 characters. Use the [ENT] soft key to shift the cursor. This method can also be used to enter a blank space in the name. If you enter a wrong character, press the [BACK] soft key until the wrong character is selected, then enter the correct character.
8. Press and hold the [ENT] soft key to save the name.
9. Press the [QUIT] soft key several times to return to radio operation.

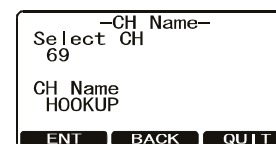
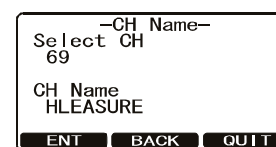
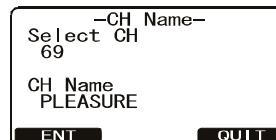
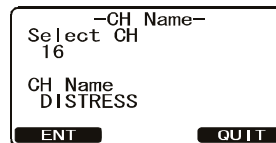

6. ATIS SETUP

The FM-4721 supports the ATIS (Automatic Transmitter Identification System) used in Inland waterways in Europe. When enabled, the ATIS mode transmits a unique ATIS code each time the microphone's **PTT** switch is released at the end of a transmission. Users should check with their local marine regulatory authority in their country for assistance in obtaining an ATIS code. "ATIS" appears on the display when the ATIS mode is active.

6.1 ATIS Code Programming

1. Press and hold down the **CALL/MENU** key until the [Setup Menu] appears.
2. Rotate the **CH** knob to select [ATIS Setup] menu then press the [SELECT] soft key.
3. Select [ATIS Code] with the **CH** knob then press the [SELECT] soft key.
4. Press applicable keys to enter your ATIS (ten digits). (If you made an error when you entered the ATIS, press the [BACK] soft key until the wrong number is selected, then press the correct numeric key.)
5. Press and hold the [ENT] soft key. The radio asks you to input the ATIS number again. Do step 4 above to enter the number again. Press and hold the [ENT] soft key.
6. Enter the number. Press the [OK] soft key to store the ATIS number in the memory.
7. Press the [QUIT] soft key several times to return to radio operation.

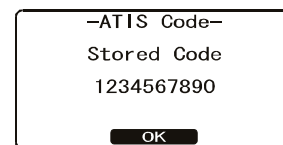
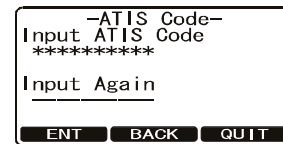
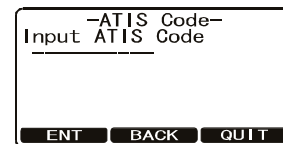



6.2 ATIS Channel Group

The FM-4721 has the capability to turn on and off the ATIS feature for each channel Group call but operator must select only INTL channel group.

1. Press and hold down the **CALL/MENU** key until the [Setup Menu] appears.
2. Rotate the **CH** knob to select [ATIS Group] menu then press the [SELECT] soft key.
3. Rotate the **CH** knob to select [Group] then press the [SELECT] soft key.
4. Rotate the **CH** knob to select the channel Group call you wish to change the setting then press the [ENT] soft key.
5. Rotate the **CH** knob to select [On] or [Off].
6. Press the [ENT] soft key to store the selected setting.
7. Press the [QUIT] soft key several times to return to radio operation.



7. MAINTENANCE, TROUBLESHOOTING

 WARNING	
	ELECTRICAL SHOCK HAZARD Do not open the equipment.
	This equipment uses high voltage that can cause electrical shock. Only qualified persons can work inside the equipment.

NOTICE
Do not apply paint, anti-corrosive sealant or contact spray to plastic parts or equipment coating.
Those items contain products that can damage plastic parts and equipment coating.

7.1 General Maintenance

 CAUTION
The heatsink can get hot enough to cause a burn injury. Allow the unit to cool before doing any maintenance procedures.

The inherent quality of the solid-state components used in this transceiver should provide many years of continuous use. However, take the following precautions to prevent damage to the transceiver.

- Keep the microphone connected or the jack covered at all times to prevent corrosion of electrical contacts.
- Remove dust from the cabinet with a dry clean cloth. Do not use commercial cleaners to clean the equipment. Those cleaners can remove paint and markers.
- Check that all cables are tightly fastened. Check the cables for corrosion and rust. Connect the cables that have loosened. Replace any damaged cables.
- Never key the microphone unless an antenna or suitable dummy load is connected to the transceiver.
- The supply voltage range to the transceiver must be within 10.8 - 15.6 VDC.
- Use only FURUNO-approved accessories and replacement parts.
- Wipe the LCD carefully to prevent scratching, using tissue paper and an LCD cleaner. To remove dirt or salt deposits, use an LCD cleaner, wiping slowly with tissue paper so as to dissolve the dirt or salt. Change paper frequently so the salt or dirt does not scratch the LCD. Do not use solvents such as thinner, acetone or benzene for cleaning.
- In the unlikely event of serious problems, please contact your dealer.

7.2 Troubleshooting Chart

Symptom	Probable cause	Remedy
Transceiver cannot be powered.	No DC voltage to the transceiver, or blown fuse	<ul style="list-style-type: none"> Check the 10.8 - 15.6 VDC battery connections and the fuse. The  (power) button needs to be pressed and held to turn the radio on.
Transceiver blows fuse when connected to power supply.	Reversed polarity of power wires	Check the power cable for DC voltage, or replace the fuse (6A 250 V). Make sure the red wire is connected to the positive (+) battery post, and the black wire is connected to the negative (-) battery post. If the fuse still blows, contact your dealer.
Popping or whining noise from the speaker while engine runs.	Engine noise	Reroute the DC power cable away from the engine. Add a noise suppressor on power cable. Change to resistive spark plug wires and/or add an alternator whine filter.
Sound is not emitted from the internal or external speaker.	Accessory cable	Check the connections of the accessory cable for short circuit on external speaker cable (WHITE & SHIELD).
Sound is not emitted from the PA speaker.	Accessory cable	Check the connections of the accessory cable for short circuit on PA speaker cable. (RED & SHIELD).
Receiving station reports low transmit power, even with HIGH power.	Antenna	Have the antenna checked or test the transceiver with another antenna. If the problem persists, contact your dealer.
The message "HI BATTERY" or "LO BATTERY" appears when the power is turned on.	The power supply voltage is too high or too low.	Confirm that the connected power supply voltage is within 10.8 - 15.6 VDC.
Your position is not displayed.	Accessory cable.	Check the accessory cable connection.
	Setting of the GPS receiver	Check the output signal format of the GPS receiver. This radio requires the GLL, RMB, or RMC sentence as an output signal. If baud rate and parity can be set on the GPS receiver, select them to 4800 and NONE, respectively.

7.3 How to Replace the Fuse

If the power cannot be turned on, the fuse may have blown. To take out the fuse from the fuse holder on the power cable, hold both ends of the fuse holder and pull the fuse holder apart without bending the fuse holder. When you replace the fuse, confirm that the fuse is tightly fixed on the metal contact located inside the fuse holder. If the metal contact holding the fuse is loose, the fuse holder may become hot.

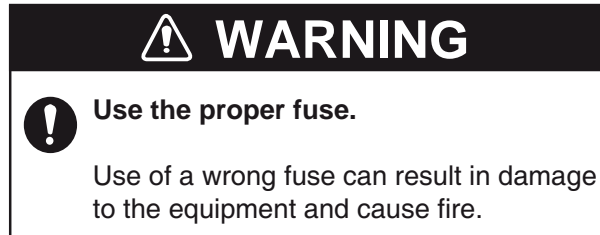

7.4 How to Clear the Memory

To clear the scan memory and preset memory:

1. Turn the radio off.
2. Press and hold down the three soft keys then turn on the radio.

7.5 How to Reset the Microprocessor

To clear all memories and other settings to factory defaults (except the Channel Group, MMSI number, Individual Directory and Group Directory), follow the procedure shown below. The display shows "EE-PROM Resetting" while the resetting is being done.

1. Turn the radio off.
2. Press and hold the **16/9**, **CALL/MENU**, and **CLR/WX** keys then turn on the radio.

7.6 Daily Test

The daily test is an FSK loop test that sends a dummy DSC message to check if the message is sent and received correctly.

1. Long push the **CALL/MENU** key to show the [Setup] Menu.
2. Rotate the **CH** knob to select [Daily Test] then press the [Select] soft key.

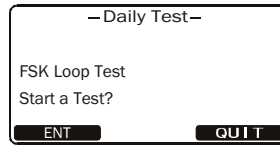

3. Push the [ENT] soft key to start the test.

The message "Testing" appears momentarily then "Check OK" or "Check NG" (No Good) appears. If NG appears, request service.

8. INSTALLATION

8.1 Transceiver Unit

The transceiver unit can be mounted on a desktop or overhead, or flush mounted in a panel. Choose a mounting location considering the points mentioned below.

- Follow the compass safety distance shown in the safety Instructions to avoid any interference to the compass from the speaker magnet in the transceiver.
- Select a location which provides easy access to the front panel controls.
- The location has space for installation of a microphone hanger.
- Choose a mounting location that is at least 1 m away from the radio's antenna.
- **CAUTION: The heatsink can get hot enough to cause a burn injury. Select a location where it cannot be easily touched.**

Note: To insure the radio does not affect the compass and the radio's performance is not affected by the antenna location, temporarily locate the radio in the desired location and:

- a) Examine the compass to see if the radio interferes with the compass.
- b) Connect the antenna and transmit. Check to ensure the radio is operating correctly by requesting a radio check.

8.1.1 Desktop or overhead mount

The supplied mounting bracket permits desktop or overhead mounting.

Use a 5 mm bit to drill the holes to a surface that is more than 10 mm thick and can support the unit's weight (1.5 kg). Fasten the bracket with the supplied screws, spring washers, flat washers, and nuts.

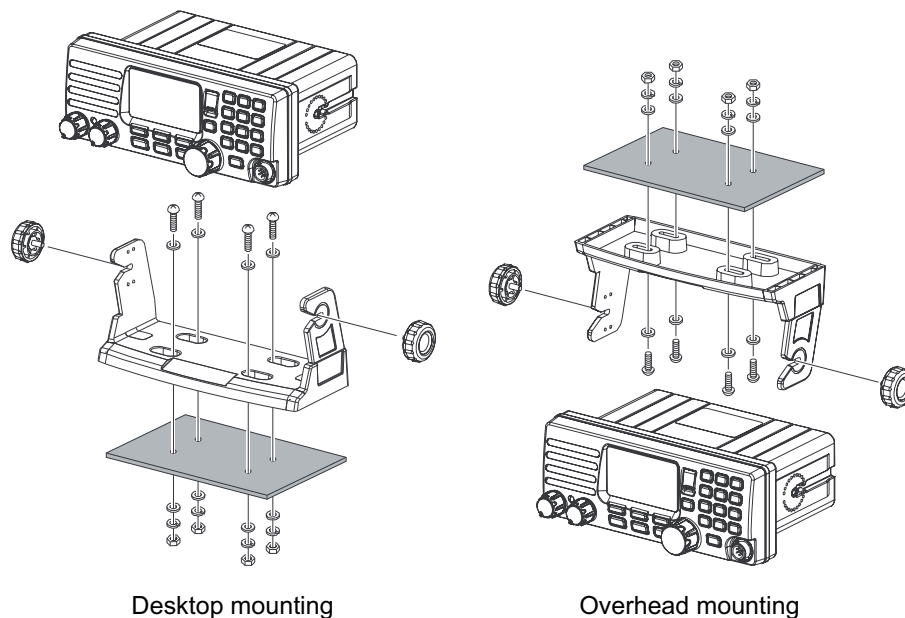

8.1.2 Flush mount (option)

Requires the MMB-84 flush mount bracket.

1. Make a rectangular template for the flush mount measuring 65×161 mm.
2. Use the template to mark the location where the rectangular hole is to be cut. Confirm that the space behind the dash or panel is deep enough to accommodate the transceiver (at least 177 mm deep). There must be at least 150 mm between the transceiver's heatsink and any wiring, cables or structures.
3. Cut out the rectangular hole and insert the transceiver.
4. Fasten the brackets to the sides of the transceiver with the lock-washer screw combination.
5. Turn the adjusting screws to adjust the tension so that the transceiver is tight against the mounting surface.

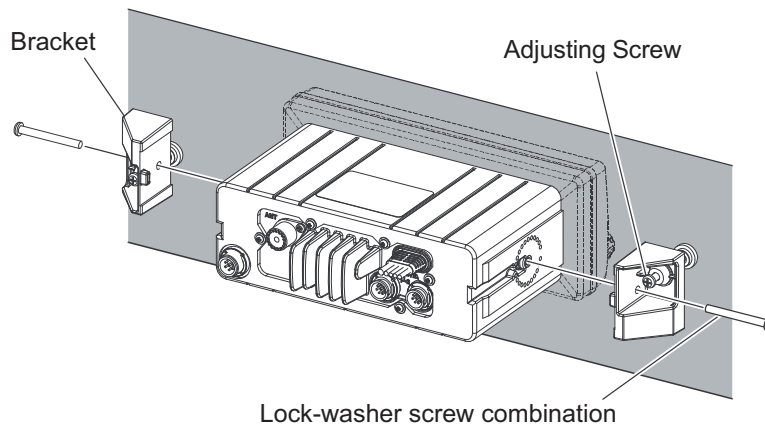

8.2 Antenna

Marine antennas are made to radiate signals equally in all horizontal directions, but not straight up. The objective of a marine antenna is to enhance the signal toward the horizon. The degree to which this is accomplished is called the antenna's gain. It is measured in decibels (dB) and is one of the major factors in choosing an antenna. In terms of effective radiated power (ERP), antennas are rated on the basis of how much gain they have over a theoretical antenna with zero gain. A 1 m, 3 dB gain antenna represents twice as much gain over the imaginary antenna.

Typically a 1 m 3 dB gain stainless steel whip is used on a sailboat mast. The longer 2.5 m 6 dB fiberglass whip is primarily used on power boats that require the additional gain.

8.3 Coaxial Cable

The VHF antenna is connected to the transceiver by means of a coaxial cable - a shielded transmission line. Coaxial cable is specified by its diameter and construction.

For runs less than 6 m, RG-58/U, which is approx. 1/4 inch in diameter, is a good choice. For runs over 6 m but less than 15 m, use the larger RG-8X or RG-213/U. For cable runs over 15 m, use RG-8X. See the figure below for how to attach the connector to the cable.

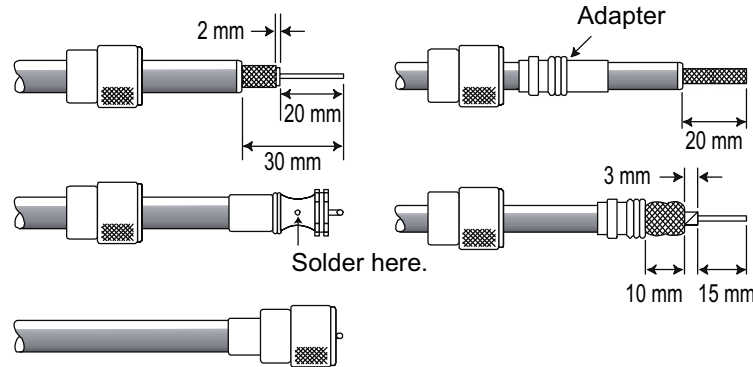

To get your coaxial cable through a fitting and into your boat's interior, you may have to cut off the end plug and reattach it later. You can do this if you follow the directions that come with the connector. Be sure to make good soldered connections.

8.4 Electrical Connections

Connect the power cable, handset and antenna to the radio. The antenna and power supply connections are as follows:

1. Mount the antenna at least 1 m away from the radio. At the rear of the radio, connect the antenna cable. The antenna cable must have a PL259 connector attached. Use coaxial cable RG-8/U if the antenna is 7.6 m or more from the radio. Use RG58 for distances less than 7.6 m.
2. Connect the red power wire to the positive terminal of the power source. Connect the black power wire to a negative ground.

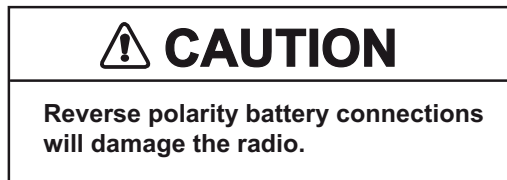

3. Connect the handset to the remote connector on the rear panel.
4. If an external speaker is used, refer to section 8.5 for the connection.
5. It is advisable to have a certified marine technician check the power output and the standing wave ratio of the antenna after installation.

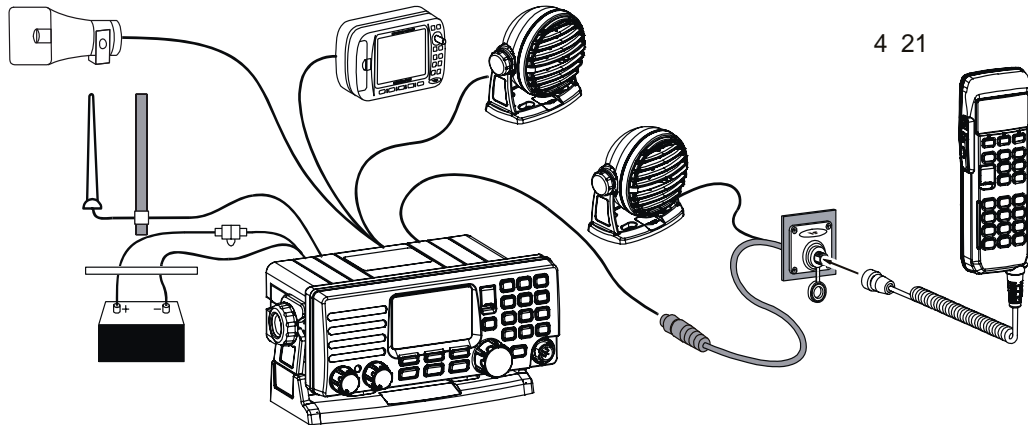

How to attach ferrite core

To suppress RF interference that can cause abnormal operation of the transceiver, attach the supplied three ferrite cores to the Accessory Cable/Power Cable and Extension Cable, then snap its two halves together, as shown in the illustration below.

Attach each ferrite core as close as possible to the transceiver body, as shown. Finally, wind some plastic tape around each ferrite core, to prevent vibration from causing the two halves to split apart.

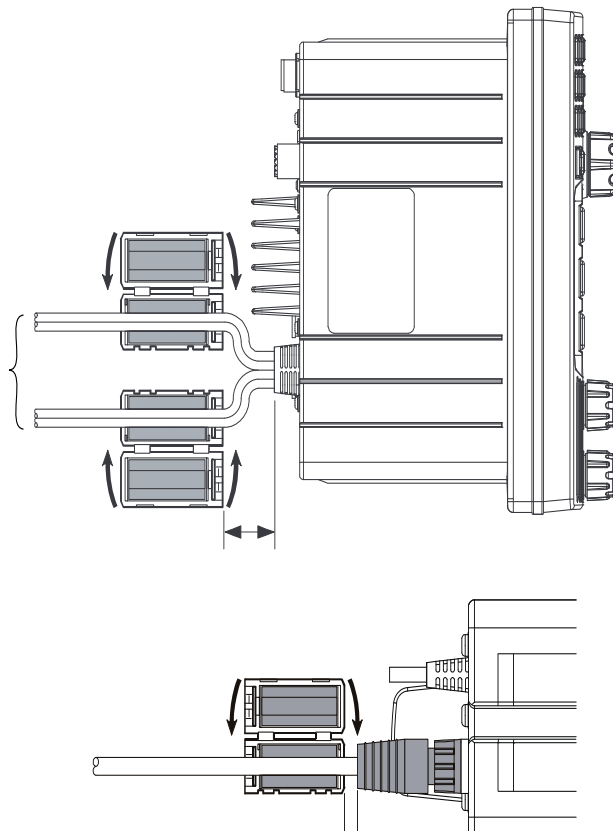

8.5 Accessory Cable

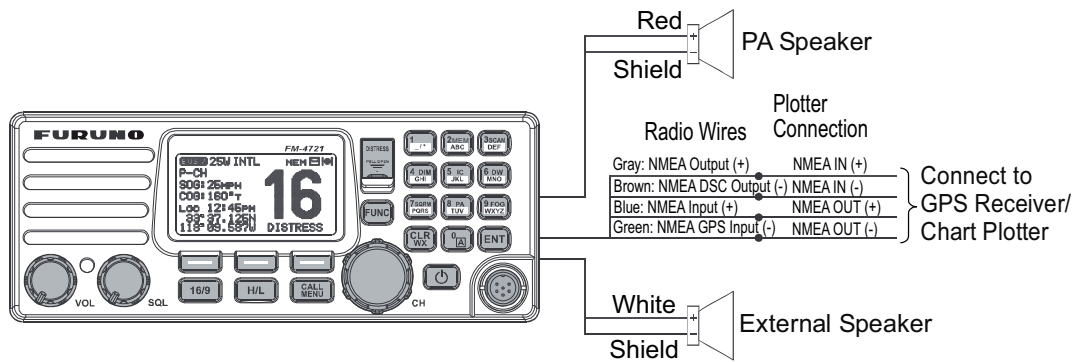

Wire Color/Description	Connection Examples
WHITE - External Speaker (+)	Connect to external 4-ohm audio speaker
SHIELD - External Speaker (-)	Connect to external 4-ohm audio speaker
RED - PA Speaker (+)	Connect to external 4-ohm PA speaker
SHIELD - PA Speaker (-)	Connect to external 4-ohm PA speaker
GREEN - NMEA GPS Input (-)	Connect to NMEA (-) output of GPS receiver
BLUE - NMEA GPS Input (+)	Connect to NMEA (+) output of GPS receiver
GRAY - NMEA DSC Output (+)	Connect to NMEA (+) input of GPS receiver
BROWN - NMEA DSC Output (-)	Connect to NMEA (-) input of GPS receiver

When making connections between the radio, chart plotter, GPS receiver, ensure that the connections are tight and protected from shorting and the units are grounded. Whether flush mounting the radio or not, it is recommended that a waterproof 8-position screw terminal connector block be fixed to the bulkhead adjacent to the rear of the radio and the connections to and from the radio are made via this connector block.

Note: In some areas powerful AM broadcast stations may be heard when in the listen-back mode. If this occurs, change the speaker wire to 2-conductor shielded audio cable. See the illustration below for connections.

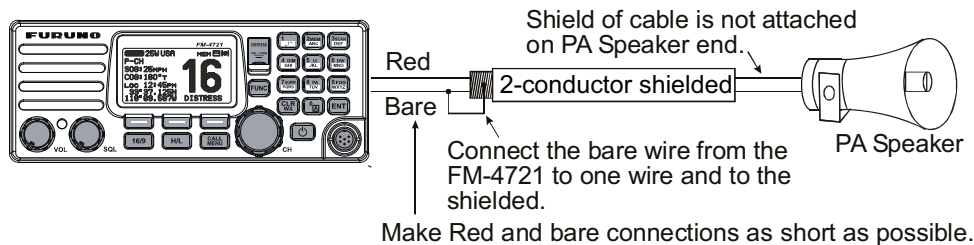

PS connections 4 based

NMEA INPUT (GPS Information)

- The PS receiver must have the NMEA Output turned on and set to 400 baud in the Setup menu. If there is a selection for PARITY, select NONE.

Wire Color/Description	Connection
E - NMEA Input (+)	PS NMEA output (+)
REEN - NMEA Input (-)	PS NMEA output (-) or common ground

- For further information on interfacing and setting up your PS receiver, contact the manufacturer of the PS receiver.
- The FM-4721 can read NMEA-0183 version 2.0 or higher.
- The NMEA 0183 input sentences are GPRMB, GPRMC, A, RMC and DSR (RMC sentence is recommended).

NMEA Output (DSC)

The NMEA 0183 output sentences are DSC and DSE.

Wire Color/Description	Connection
RA - NMEA Output (+)	Chart plotter NMEA input (+)
ROUN - NMEA Output (-)	PS NMEA input (-) or common ground

How to check PS receiver connections

After you have connected the FM-4721 to the PS receiver, your position in latitude and longitude should appear on the display. If your position does not appear, the PS icon flashes continuously. Check the connection between the radio and the PS receiver.

Note: The indication POS Data Manual appears when position is input manually.

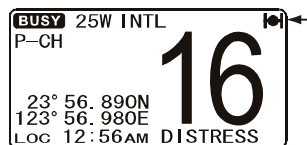

.6 Handset HS-4721

The Handset remotely controls the Radio, DSC, and PA/Fog functions. In addition, the FM-4721 can operate as a full function intercom system between the HS-4721 and the FM-4721.

1. Connect the Extension Cable to the Handset connector (eight pin) on the rear panel, then tighten the Nut (see illustration on the next page).
2. Referring to illustration on the next page, make a 30 mm hole in the wall, then insert the Extension Cable into this hole. Connect the Handset and Mounting Bracket to the Extension Cable Connector using the Nut.

3. Drill the four screw holes (approx. 2 mm in diameter) on the wall, then fasten the Mounting bracket to the wall using four self-tapping screws.
4. Put the Rubber Cap onto the Nut. The installation is now complete.

The extension cable can be cut and spliced, however care needs to be taken when reconnecting the wires to ensure watertight integrity. Before cutting the cable make sure it is not plugged into the radio. After you have cut the cable, note the following wires:

Yellow, Green, Brown, Purple, Blue, Green, Red, Shield

Note: The red wire and shield wire are wrapped in foil. Remove the foil, and separate the red wire from the shield wire.

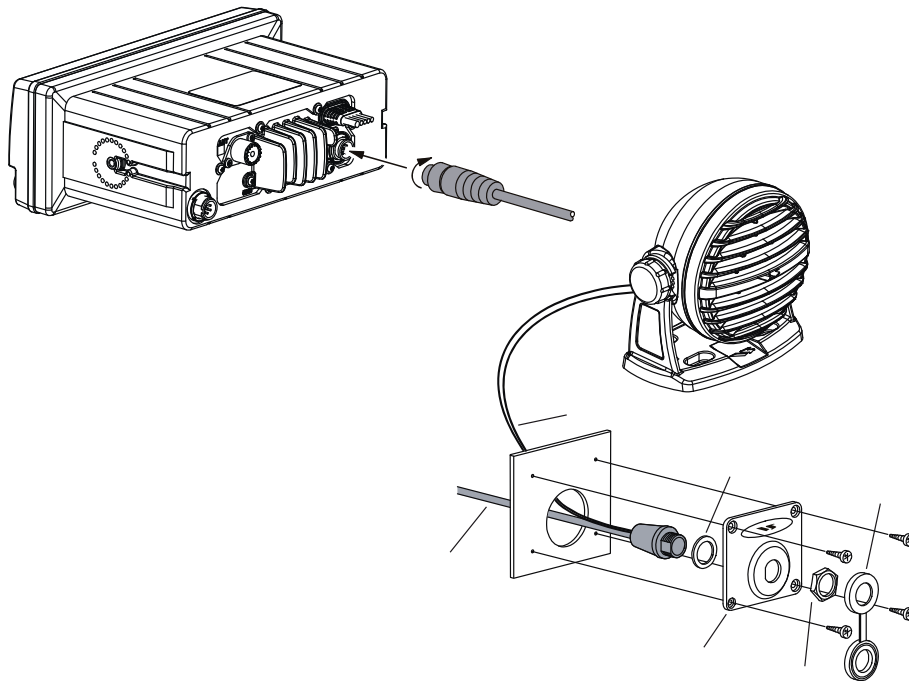

How to mount the handset cradle

Fasten the cradle to the mounting location with two self-tapping screws. Set the handset in the cradle.

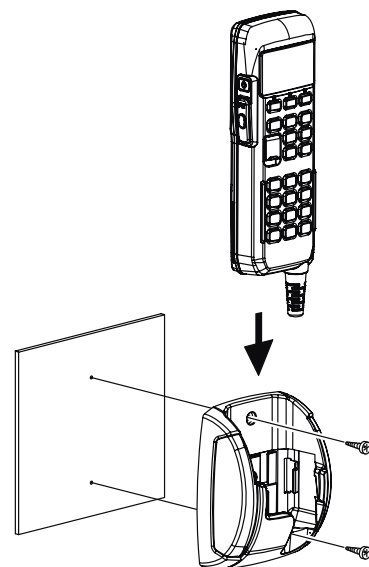

8.6.1 How to use an external speaker

The HS-4721 can drive the internal speaker or an external speaker. In noisy locations an external speaker may be connected to the white speaker wires on the HS-4721 routing cable. When connecting an external speaker, follow the procedure below to turn off the internal speaker and enable the external speaker.

1. On the HS-4721 Handset, press and hold the **CALL/MENU** key until the [Setup Menu] appears.
2. Select [General Setup] with the ▲ or ▼ key then press the [SELECT] soft key.
3. Press the ▼ key to select [EXT Speaker] then press the [SELECT] soft key.
4. Press the ▲ or ▼ key to select [On] (External speaker on) then press the [ENT] soft key to save the selection.
5. Press the [QUIT] soft key several times to quit.

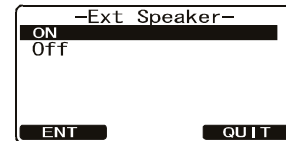
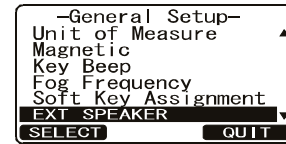

8.7 How to Set up the Equipment from the Menu

8.7.1 How to set time offset to show local time

The FM-4721 is set at the factory to show GPS satellite time or UTC time when an optional GPS receiver is connected. If you prefer to use local time, enter the time difference between your local time and UTC. The time offset must be set in order for the radio to display the current time in your area.

1. Press and hold down the **CALL/MENU** key until the [Setup Menu] appears.
2. Select [General Setup] with the **CH** knob then press the [SELECT] soft key.
3. Select [Time Offset] with the **CH** knob then press the [SELECT] soft key.
4. Rotate the **CH** knob to select the time offset of your location. See the illustration below to find your offset time. [00:00] applies no offset; the time is the same as UTC (Universal Time Coordinated or GPS Satellite Time).

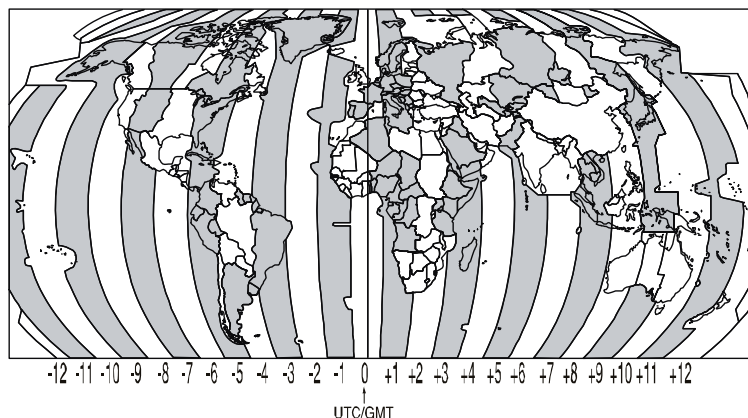
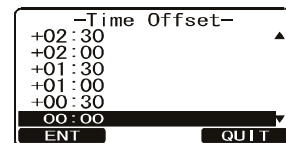

5. Press the [ENT] soft key to store the time offset.
6. Press the [QUIT] soft key several times to return to radio operation.

8.7.2 How to show local time or UTC time

You can show UTC time or local time.

1. Press and hold down the **CALL/MENU** key until the [Setup Menu] appears.
2. Select [General Setup] with the **CH** knob then press the [SELECT] soft key.
3. Rotate the **CH** knob to select [Time Area] then press the [SELECT] soft key.
4. Rotate the **CH** knob to select [UTC] or [Local] then press the [ENT] soft key to store the selected setting.
5. Press the [QUIT] soft key several times to return to radio operation.

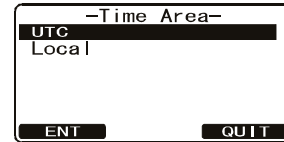

8.7.3 How to set the time notation

Time can be shown in 12-hour or 24-hour format.

1. Press and hold down the **CALL/MENU** key until the [Setup Menu] appears.
2. Select [General Setup] with the **CH** knob then press the [SELECT] soft key.
3. Rotate the **CH** knob to select [Time Display] then press the [SELECT] soft key.
4. Rotate the **CH** knob to select [12 Hour] or [24 Hour] then press the [ENT] soft key to store the selected setting.
5. Press the [QUIT] soft key several times to return to radio operation.



8.7.4 How to select GPS COG format

The GPS-measured Course Over Ground can be shown in true or magnetic bearing.

1. Press and hold down the **CALL/MENU** key until the [Setup Menu] appears.
2. Select [General Setup] with the **CH** knob then press the [SELECT] soft key.
3. Rotate the **CH** knob to select [Magnetic] then press the [SELECT] soft key.
4. Rotate the **CH** knob to select [Magnetic] or [True] then press the [ENT] soft key to store the selected setting.
5. Press the [QUIT] soft key several times to return to radio operation.

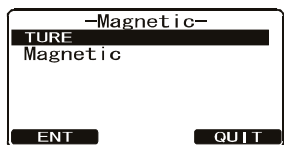

8.8 Optional Equipment

8.8.1 Bluetooth Adapter Unit BU-1

The BU-1 installs inside the transceiver and enables bluetooth compatible devices such as a bluetooth headset.

Before starting the installation, turn the transceiver off and disconnect all cables from the transceiver. Touch a metal place to discharge any static electricity from your body.

1. Unfasten six screws to remove the cover.

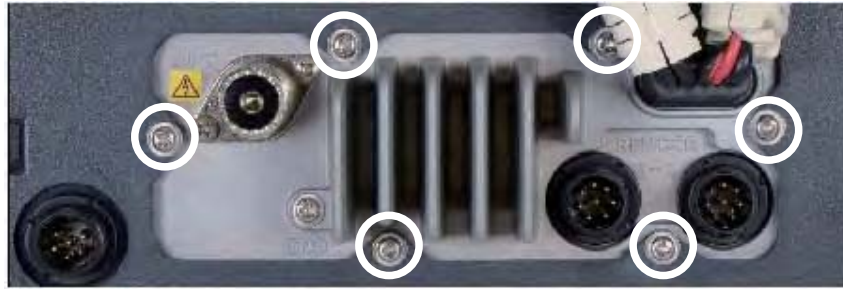

2. Unplug the connector connected between the cover and the circuit board in the transceiver. Remove the paper tape from the location shown in the figure below.

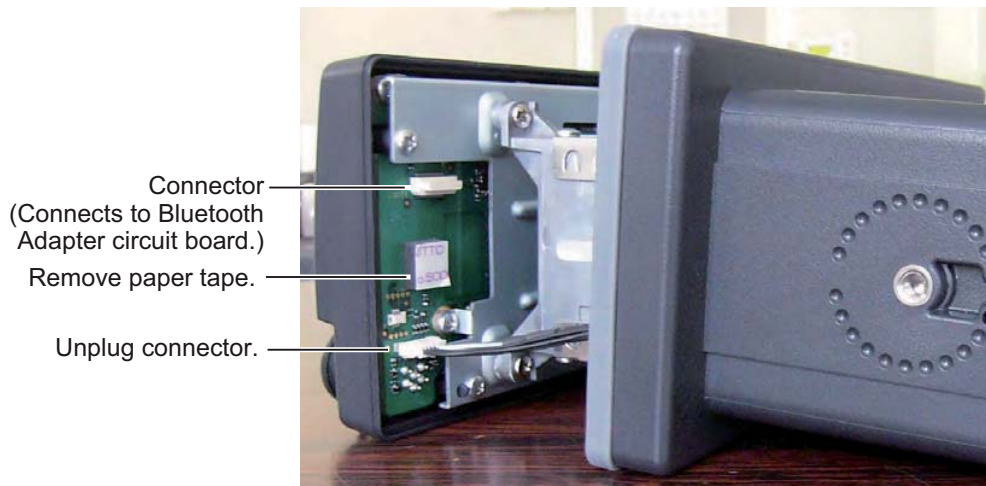

3. Mate the connector on the Bluetooth Adapter circuit board with the connector shown in the illustration above.
4. Check that the gasket at the rear of the transceiver is properly seated.



5. Set the cover to the transceiver and connect the connector to the circuit board in the transceiver.
6. Close the cover.

8.8.2 Voice Scrambler FVP-42

The Voice Scrambler installs inside the transceiver and provides private communications with an FM-4721 equipped with the FVP-42.

Before starting the installation, turn the transceiver off and disconnect all cables from the transceiver. Touch a metal place to discharge any static electricity from your body.

1. Do steps 1 and 2 in section 8.8.1 to remove the cover and unplug a connector.
2. Turn the transceiver upside down.
3. Unfasten four screws to remove the shield cover.

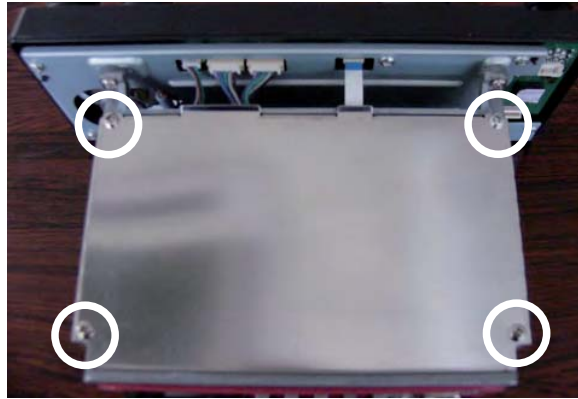

4. Referring to the figure below, remove the dummy connector and unfasten two screws. The dummy connector can be discarded. Save the screws for later use.

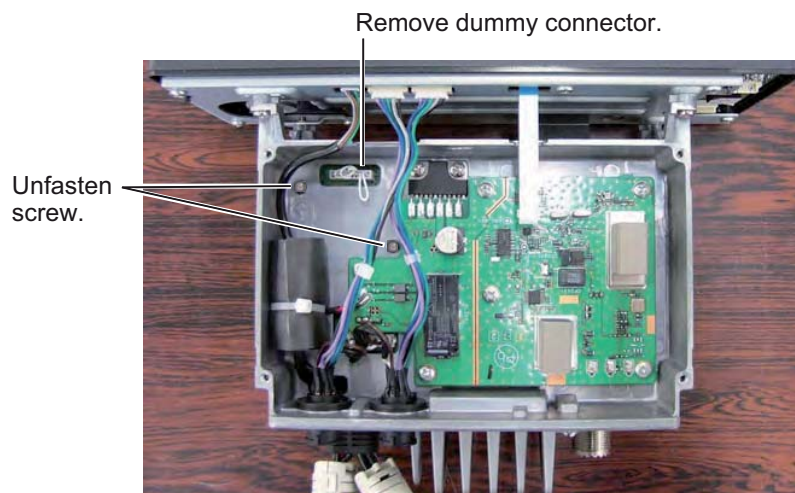

8. INSTALLATION

5. Fasten the Voice Scrambler circuit board to the transceiver with the screws unfastened at step 4. Plug in the connector from the Voice Scrambler circuit board where the dummy connector was connected.

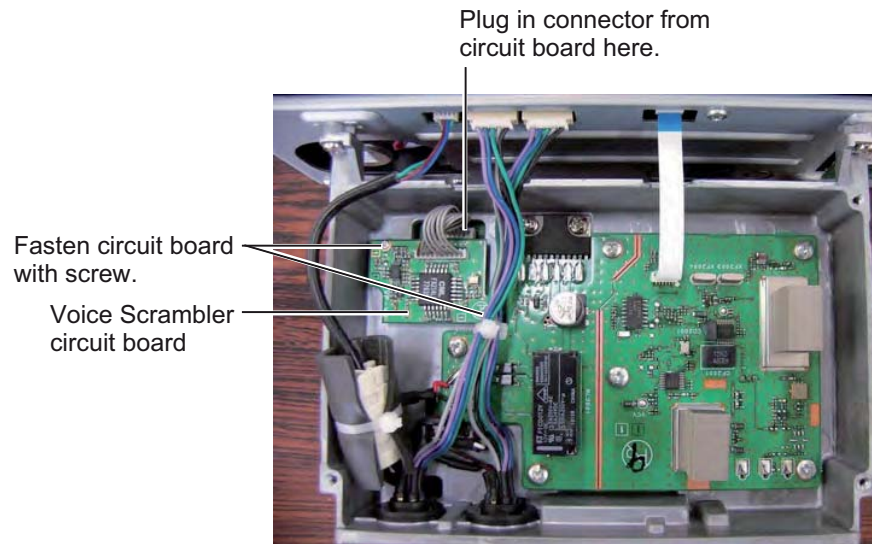

6. Close the shield cover.
7. Turn the transceiver right side up.
8. Check that the gasket at the rear of the transceiver is properly seated. (See the figure at the bottom of page 8-10.)
9. Set the cover to the transceiver and connect the connector to the circuit board in the transceiver.
10. Close the cover.

APPENDIX 1 CHANNEL ASSIGNMENTS, MENU TREE

Channel Assignments

This chapter provides the VHF Marine Channel assignments for U.S.A. and International use. Below are listed some data about the charts.

1. Channels indicated as VTS are part of the U.S. Coast Guard's Vessel Traffic System.
2. Alpha channel numbers, that is, channel numbers followed by the letter A (such as Channel 07A) are simplex channels on the U.S.A. or Canadian channel assignments whose counterparts in the International assignments are duplex channels. International channels do not use alpha numbers. If you call the Coast Guard on CH16, they may ask you to "go to channel 22 Alpha." This is a channel assigned to the U.S.A, and Canadian Coast Guards for handling distress and other calls. If your radio is set for International operation, go to Channel 22 instead of 22A, to communicate with the Coast Guard. To use Channel 22A, your radio must be set for USA or Canada operation, usually by a U/I/C (USA/International/Canada) control or combination of controls. Channel 22 (without an "A") is an International duplex channel for port operations. Some radios indicate an "A" adjacent to the alpha channels on the display; on others "alpha" is not indicated but the proper channel is selected based on the U/I/C setting.
3. Bridge-to-Bridge channels (for example, Channel 13) are for use by bridge operators on inter-coastal waterways and rivers. It is also used by marine vessels in the vicinity of these bridges for navigation and for communicating with the bridge operators. Note that a limit of 1 Watt is specified for these channels.
4. The S/D column on the chart indicates either S (simplex) or D (duplex). Simplex means transmitting and receiving on the same frequency. Only one party at a time can talk, unlike a telephone. Be sure to say "over" and release your microphone push-to-talk switch at the end of each transmission. Duplex operation involves the use of one frequency for transmitting and a the other frequency for receiving. On channels specified as duplex on the charts, correct mode of operation is established automatically by your radio when you select a channel; you cannot change the mode. Release the push-to-talk switch after each transmission in order to listen to the radio.
5. Channels normally used by recreational boaters are those that include the term "non-commercial" in the Channel Use column of the chart. Some of these are shared with other users and some are used only in certain geographic regions.
6. Marine vessels equipped with VHF radios are required to monitor CH16.

VHF marine channel chart

CH	U	C	I	S/D	TX	RX	Channel use
01		X	X	D	156.050	160.650	Public Correspondence (Marine Operator)
01A	X			S	156.050		Port Operation and Commercial. VTS in selected areas
02		X	X	D	156.100	160.700	Public Correspondence (Marine Operator)
03		X	X	D	156.150	160.750	Public Correspondence (Marine Operator)
03A*	X			S	156.150		U.S. Government Only, Coast Guard
04			X	D	156.200	160.800	Public Correspondence (Marine Operator), Port operation, ship movement

APPENDIX 1 CHANNEL ASSIGNMENTS, MENU TREE

CH	U	C	I	S/D	TX		RX	Channel use
04A		X		S	156.200			Pacific coast: Coast Guard, East Coast: Commercial fishing
05			X	D	156.250	160.850		Public Correspondence (Marine Operator), Port operation, ship movement
05A	X	X		S	156.250			Port operation. VTS in Seattle
06	X	X	X	S	156.300			Inter-ship Safety
07			X	D	156.350	160.950		Public Correspondence (Marine Operator), Port operation, ship movement
07A	X	X		S	156.350			Commercial
08	X	X	X	S	156.400			Commercial (Inter-ship only)
09	X	X	X	S	156.450			Boater Calling channel, Commercial & Non-commercial (Recreational)
10	X	X	X	S	156.500			Commercial
11	X	X	X	S	156.550			Commercial. VTS in selected areas.
12	X	X	X	S	156.600			Port operation. VTS in selected areas.
13	X	X	X	S	156.650			Inter-ship Navigation Safety (Bridge-to-bridge)
14	X	X	X	S	156.700			Port operation. VTS in selected areas.
15	X			S	-	156.750		Environmental (Receive only)
15		X	X	S	156.750			Commercial, non-commercial, ship movement (1 W)
16	X	X	X	S	156.800			International Distress, Safety and Calling
17	X	X	X	S	156.850			State Controlled (1 W)
18			X	D	156.900	161.500		Port operation, ship movement
18A	X	X		S	156.900			Commercial
19			X	D	156.950	161.550		Port operation, ship movement
19A	X			S	156.950			US: Commercial
19A		X		S	156.950			Coast Guard
20	X	X	X	D	157.000	161.600		Canadian Coast Guard Only, International: port operations and shipment
20A	X			S	157.000			Port operation
21			X	D	157.050	161.650		Port operation, ship movement
21A*	X	X		S	157.050			U.S. Government Only, Canadian Coast Guard
22			X	D	157.100	161.700		Port operation, ship movement
22A	X	X		S	157.100			US and Canadian Coast Guard Liaison and Maritime Safety Information Broadcasts announced on channel 16
23		X	X	D	157.150	161.750		Public Correspondence (Marine Operator)
23A*	X			S	157.150			U.S. Government Only
24	X	X	X	D	157.200	161.800		Public Correspondence (Marine Operator)
25	X	X	X	D	157.250	161.850		Public Correspondence (Marine Operator)
26	X	X	X	D	157.300	161.900		Public Correspondence (Marine Operator)
27	X	X	X	D	157.350	161.950		Public Correspondence (Marine Operator)
28	X	X	X	D	157.400	162.000		Public Correspondence (Marine Operator)
60		X	X	D	156.025	160.625		Public Correspondence (Marine Operator)
61			X	D	156.075	160.675		Public Correspondence (Marine Operator), Port operation, ship movement
61A*	X	X		S	156.075			Public Coast: Coast Guard; East Coast: commercial fishing only

APPENDIX 1 CHANNEL ASSIGNMENTS, MENU TREE

CH	U	C	I	S/D	TX	RX	Channel use
62			X	D	156.125	160.725	Public Correspondence (Marine Operator), Port operation, ship movement
62A		X		S	156.125		Public Coast: Coast Guard; East Coast: commercial fishing only
63			X	D	156.175	160.775	Public Correspondence (Marine Operator), Port operation, ship movement
63A	X	X		S	156.175		Port Operation and Commercial. VTS in selected areas.
64		X	X	D	156.225	160.825	Public Correspondence (Marine Operator), Port operation, ship movement
64A*	X	X		S	156.225		Public Correspondence (Marine Operator), Port operation, ship movement
65			X	D	156.275	160.875	Public Correspondence (Marine Operator), Port operation, ship movement
65A	X	X		S	156.275		Port Operations
66			X	D	156.325	160.925	Public Correspondence (Marine Operator), Port operation, ship movement
66A	X	X		S	156.325		Port Operations
67	X	X	X	S	156.375		US: Commercial. Used for Bridge-to-bridge communications in lower Mississippi River. Intership only, Canada: Commercial fishing, S&R
68	X	X	X	S	156.425		Non-commercial (Recreational)
69	X	X	X	S	156.475		US: Non-commercial (Recreational), Canada: Commercial fishing only, International: Inter-ship, Port operations and Ship movement
70	X	X	X	S	156.525		Digital selective calling (voice communica- tions not allowed)
71	X	X	X	S	156.575		US, Canada: Non-commercial (Recreation- al), International: Port operations and Ship move- ment
72	X	X	X	S	156.625		Non-commercial (Inter-ship only)
73	X	X	X	S	156.675		US: Port Operations, Canada: Commercial fishing only, International: Inter-ship, Port operations and Ship movement
74	X	X	X	S	156.725		US: Port Operations, Canada: Commercial fishing only, International: Inter-ship, Port operations and Ship movement
75	X	X	X	S	156.775		Port Operations (Inter-ship only) (1W)
76	X	X	X	S	156.825		Port Operations (Inter-ship only) (1W)
77	X	X		S	156.875		Port Operations (Inter-ship only) (1W)
77			X	S	156.875		Port Operations (Inter-ship only)
78			X	D	156.925	161.525	Public Correspondence (Marine Operator), Port operation, ship-movement
78A	X	X		S	156.925		Non-commercial (Recreational)
79			X	D	156.975	161.575	Port operation and Ship movement
79A	X	X		S	156.975		Commercial
80			X	D	157.025	161.625	Port operation, ship movement

APPENDIX 1 CHANNEL ASSIGNMENTS, MENU TREE

CH	U	C	I	S/D	TX	RX	Channel use
80A	X	X		S	157.025		Commercial
81			X	D	157.075	161.675	Port operation, ship movement
81A*	X			S	157.075		U.S. Government Only -Environmental protection operations.
81A		X		S	157.075		Canadian Coast Guard Only
82			X	D	157.125	161.725	Public Correspondence (Marine Operator), Port operation, ship movement
82A*	X	X		S	157.125		U.S. Government Only, Canadian Coast Guard Only
83		X		D	157.175	161.775	Canadian Coast Guard Only
83			X	D	157.175	161.775	Public Correspondence (Marine Operator)
83A*	X	X		S	157.175		U.S. Government Only, Canadian Coast Guard Only
84	X	X	X	D	157.225	161.825	Public Correspondence (Marine Operator)
85	X	X	X	D	157.275	161.875	Public Correspondence (Marine Operator)
86	X	X	X	D	157.325	161.925	Public Correspondence (Marine Operator)
87		X	X	S	157.375		Port operation, ship movement
87A	X			S	157.375		Public Correspondence (Marine Operator)
88		X	X	S	157.425		Port operation, ship movement
88A	X			S	157.425		Commercial, Inter-ship Only
WX01	X	X	X	D	-	162.550	Weather (receive only)
WX02	X	X	X	D	-	162.400	Weather (receive only)
WX03	X	X	X	D	-	162.475	Weather (receive only)
WX04	X	X	X	D	-	162.425	Weather (receive only)
WX05	X	X	X	D	-	162.450	Weather (receive only)
WX06	X	X	X	D	-	162.500	Weather (receive only)
WX07	X	X	X	D	-	162.525	Weather (receive only)
WX08	X	X	X	D	-	161.650	Weather (receive only)
WX09	X	X	X	D	-	161.775	Weather (receive only)
WX10	X	X	X	D	-	163.275	Weather (receive only)

*: Simplex channels, 3A, 21A, 23A, 61A, 64A, 81A, 82A and 83A cannot be lawfully used by the general public in U.S.A. waters.

Menu Tree (default settings shown in bold italic)

DSC menu

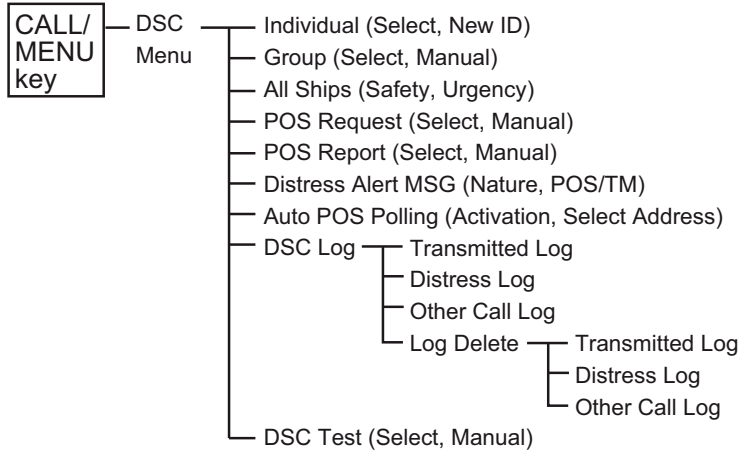

Setup menu

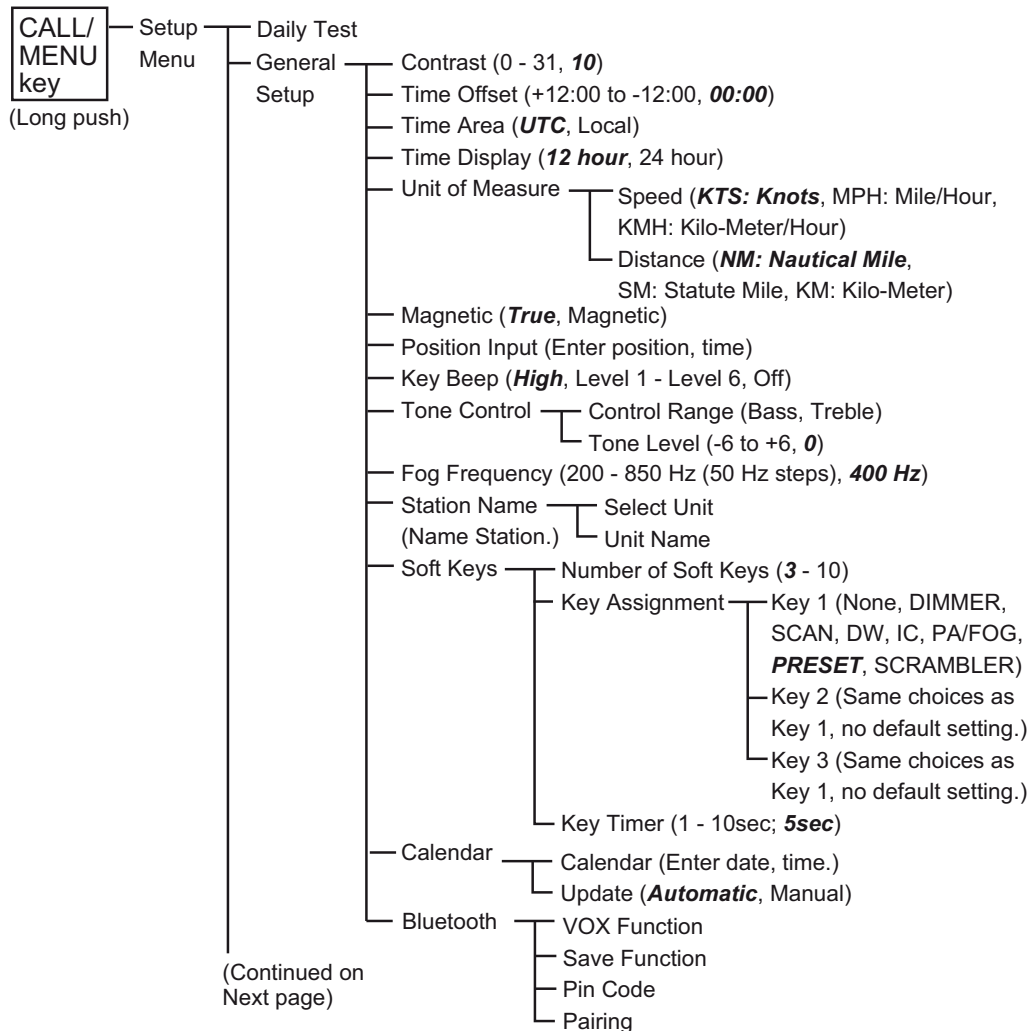

(Continued from previous page)

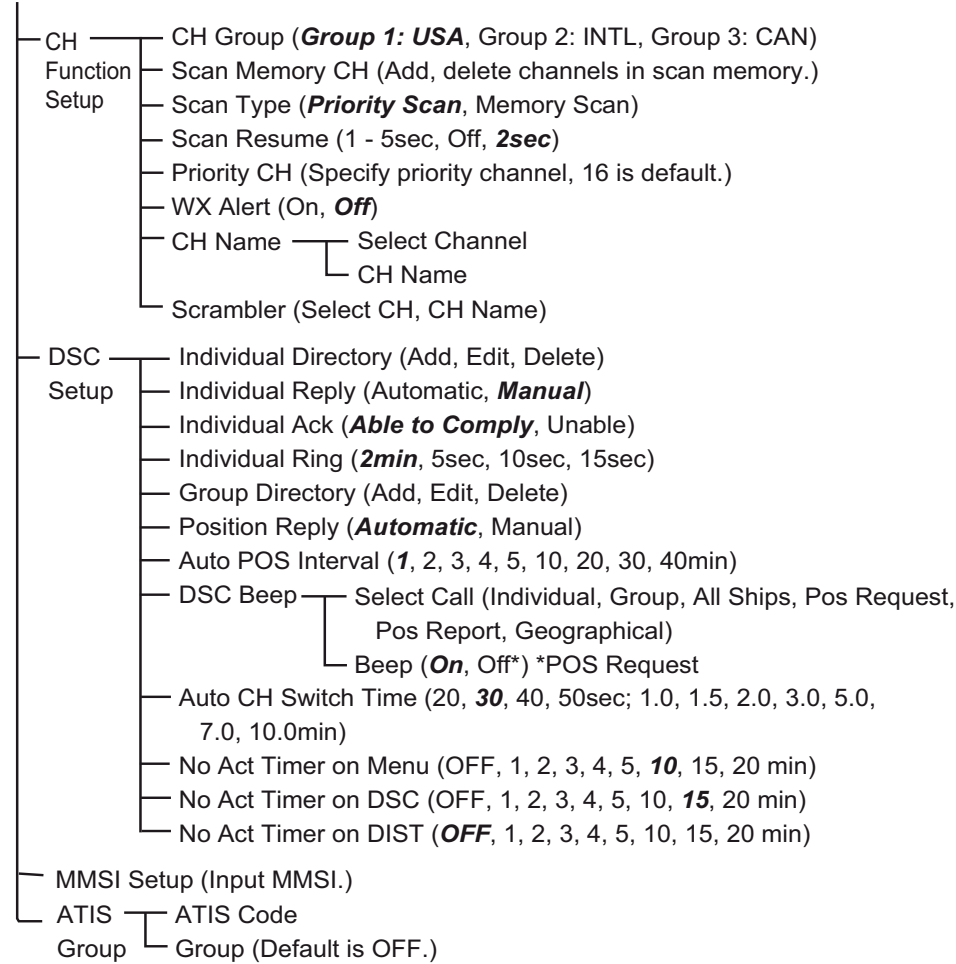

**SP C CAT NS MAR N H RAD T L PH N
M-4721**

1 GENERAL

- 1.1 Channels SA, International and Canadian
- 1.2 Input voltage 12.0 VDC
- 1.3 Operating voltage range 10. to 15.6 VDC
- 1.4 Current drain Standby: 0.5 A, Receive: 1.5 A, Transmit: 6.0 A (Hi), 2.5 A (Lo)

2 TRANSMITTER

- 2.1 Frequency range 156.025 to 157.425 MHz
- 2.2 RF output power 25 (Hi) 1 (Lo)
- 2.3 Conducted spurious emissions less than 0.25
- 2.4 Audio response within 1/3 of a 6 dB/octave pre-emphasis characteristic at 300 to 3000 Hz
- 2.5 Audio distortion 5
- 2.6 Modulation 16 0 3E, for DSC 16 0 2
- 2.7 Frequency stability 0.0005 (15°C to 55°C)
- 2.8 FM hum and noise 40 dB

3 RECEIVER

- 3.1 Frequency range 156.050 to 163.275 MHz
- 3.2 Sensitivity 20dB quieting: 0.30 V
12 dB SINAD: 0.25 V
Squelch sensitivity: 0.13 V
- 3.3 Modulation acceptance bandwidth ±7.5 kHz
- 3.4 Selectivity Spurious and image rejection: -70 dB
Intermodulation and rejection: -6 dB
- 3.5 Audio output 2, 4 ohm

4 ENVIRONMENTAL CONDITIONS

- 4.1 Ambient temperature -15°C to 55°C
- 4.2 Relative humidity 93% or less at 40°C
- 4.3 Degree of protection Transceiver unit IP 7 (front panel), IP 4 (rear panel)
Handset IP 7
- 4.4 Vibration IEC 60945 Ed.4

This page is intentionally left blank.

INDEX

Numerics

0 key.....	2-2
16/9 key.....	2-1
2/MEM key.....	2-2
3/SCAN key.....	2-2
4/DIM key.....	2-2, 2-6
5/IC key.....	2-2, 2-13
6/DW key.....	2-2, 2-8
7/SQRM key.....	2-2, 2-16
8/PA key.....	2-2, 2-11
9/FOG key.....	2-2, 2-12

A

All ships call	
receiving.....	3-7
transmitting.....	3-6
ATIS	
ATIS code.....	6-1
channel group.....	6-2
Audio tone.....	4-4

B

Bluetooth	
battery saver.....	2-16
operation.....	2-15
pairing.....	2-14
VOX operation.....	2-15

C

Calendar.....	4-7
CALL/MENU key.....	2-1
Calls	
emergency.....	1-1
other vessel.....	1-1
CH group.....	5-1
CH key.....	2-2
CH13.....	1-2
CH67.....	1-2
Channel mode (Int., Canada, USA).....	2-6
Channel naming.....	5-4
Channel preset	
activation.....	2-11
delete channel.....	2-11
procedure.....	2-10
Channel switch time.....	3-24
CLR/WX key.....	2-2, 2-7
COG format.....	4-3
Contrast.....	4-1

D

Daily test.....	7-4
Dimmer.....	2-6
Distress alert	
canceling.....	3-5
pausing.....	3-5
receiving.....	3-5

transmitting, nature not specified.....	3-2
transmitting, nature specified.....	3-3
transmitting, with manual position.....	3-4
DISTRESS key.....	2-2, 3-2, 3-4
DSC distress call log.....	3-13
DSC log	
deleting calls.....	3-14
DSC distress call log.....	3-13
other call log.....	3-13
transmitted DSC call log.....	3-13
DSC polling	
enable/disable.....	3-24
interval between position requests.....	3-23
stations to poll.....	3-23
DSC test call	
making with manually entered MMSI....	3-26
making with MMSI in Individual	
Directory.....	3-25
Dual watch.....	2-8

E

Emergency call.....	1-1
ENT key.....	2-2
External speaker.....	8-8

F

Fog alert frequency.....	4-4
FOG HORN.....	2-12
FUNC key.....	2-2
Fuse replacement.....	7-3

G

Group call	
Group Directory.....	3-14
receiving.....	3-17
transmitting to manually entered	
Directory.....	3-16

H

H/L key.....	2-1
--------------	-----

I

Individual call	
call acknowledge method.....	3-9
Individual Call Directory.....	3-7
receiving, automatic.....	3-11
receiving, manual.....	3-12
reply method.....	3-8
ringer.....	3-9
transmitting to manually entered MMSI.	3-10
transmitting to MMSI in Individua	
Directory.....	3-10
Individual Directory.....	3-7
Intercom	
calling.....	2-14
communication.....	2-13

INDEX

K

Key beep4-4

L

Local time4-2

M

Maintenance7-1

Memory clear7-3

Memory scanning2-9

Microprocessor reset7-3

MMSI

description3-1

entry of3-1

N

Naming station, handset4-5

NOAA weather channels

selection of2-7

weather alert2-7

weather alert test2-7

O

Other call log3-13

P

PA HAIL2-11

Position input (manual)4-3

Position report

receiving3-22

ringer3-20

transmitting to manually entered MMSI..3-21

transmitting to MMSI in Individual

Directory3-21

Position request

receiving3-20

reply setup3-18

ringer3-18

transmitting to manually entered MMSI..3-19

transmitting to MMSI in Individual

Directory3-19

Priority CH5-2

Priority scanning2-10

PWR key2-2

R

Reception2-5

S

Scan memory2-9

Scanning

memory scanning2-9

priority scanning2-10

programming scan memory2-9

resuming5-2

scan memory programming5-1

scan type2-8, 5-2

Soft keys

function2-1

programming, handset4-7

programming, transceiver unit4-6

SQL control2-1

T

Telephone call1-2

Time notation4-2

Time offset4-1

Timeout4-9

Transmission2-5

Transmit timeout timer2-6

Transmitted DSC call log3-13

Troubleshooting7-2

U

Units of measurement4-2

UTC time4-2

V

Voice scrambler2-16

VOL control2-1

VOX operation2-15

W

Weather alert5-3

Declaration of Conformity



We **FURUNO ELECTRIC CO., LTD.**

(Manufacturer)

9-52 Ashihara-Cho, Nishinomiya City, 662-8580, Hyogo, Japan

(Address)

declare under our sole responsibility that the product

MARINE VHF RADIOTELEPHONE FM-4721

(Model name, type number)

is in conformity with the essential requirements as described in the Directive 1999/5/EC of the European Parliament and of the Council of 9 March 1999 on radio equipment and telecommunications terminal equipment (R&TTE Directive) and satisfies all the technical regulations applicable to the product within this Directive

IEC 60945 Ed.4.0: 2002 EMC related items	EN 301 025-1 V1.4.1: 2010
IEC 60950-1 Ed.2.0: 2005 Safety related items	EN 301 025-2 V1.4.1: 2010
IEC 60950-1 Ed.2.0 A1: 2009 Safety related items	EN 301 025-3 V1.4.1: 2010
EN 300 698-1 V1.4.1: 2009	EN 301 843-1 V1.2.1: 2004
EN 300 698-2 V1.2.1: 2009	EN 301 843-2 V1.2.1: 2004
EN 300 698-3 V1.2.1: 2009	

(title and/or number and date of issue of the standard(s) or other normative document(s))

For assessment, see

- Statement of Opinion No.11214014 issued by Telefication, The Netherlands.

On behalf of Furuno Electric Co., Ltd.

Takahiko Kusuda
Manager, QMS Secretariat
Quality Assurance Department

Nishinomiya City, Japan
May 24, 2011

(Place and date of issue)

(name and signature or equivalent marking of authorized person)

ECF

(Elemental Chlorine Free)

The paper used in this manual
is elemental chlorine free.

FURUNO ELECTRIC CO., LTD.

9-52, Ashihara-cho,
Nishinomiya, 662-8580, JAPAN

Telephone: +81-(0)798-65-2111
Fax: +81-(0)798-65-4200

•FURUNO Authorized Distributor Dealer

All rights reserved.

Printed in Japan

A1 :MAY 2011

Pub. No. OME-56840-A1
FM-4721